

SAW CUT SQUARE AND REMOVE PAVEMENT 12-INCHES MINIMUM LARGER THAN MANHOLE FRAME DIMENSION. CONFIGURE THE SAWCUT SO THAT THE PATCH IS DIAMOND SHAPED IN THE DIRECTION OF TRAFFIC.

REPLACE WITH MIN. 4-INCH THICK PAVING AC. CLASS SHALL MATCH THE SURROUNDING PAVEMENT. (MAY BRING CONCRETE TO SURFACE IF APPROVED BY ENGINEER)

APPLY TACK COAT TO EDGES OF EXISTING PAVEMENT BEFORE INSTALLING PATCH. FINISH JOINT WITH ASPHALTIC SEAL AND SAND.

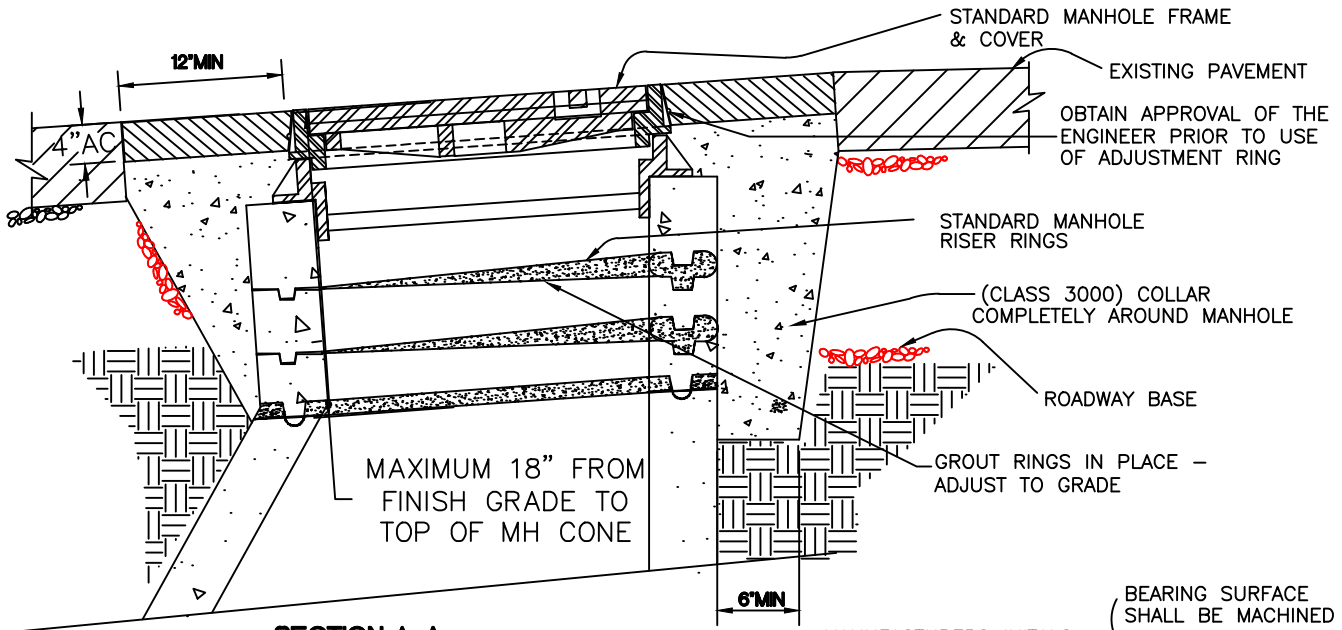

SECTION A-A
TYPICAL MANHOLE GRADE ADJUSTMENT IN STREET

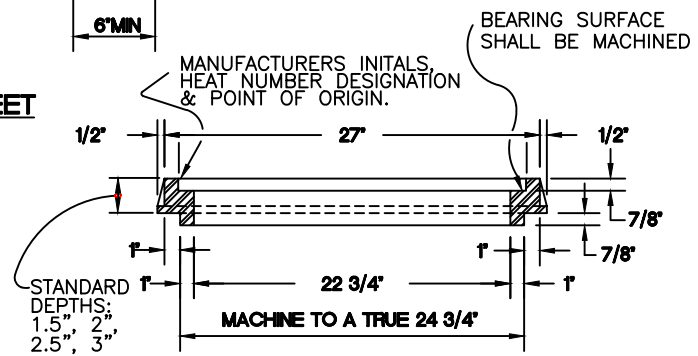

SECTION B-B

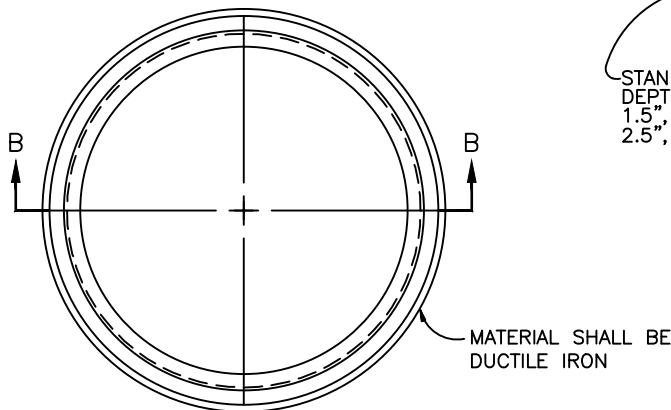

MANHOLE ADJUSTMENT RINGS FOR RESURFACING

CITY OF SANDY

MANHOLE ADJUSTMENT DETAILS

DATE: NOV 1997

DRAWING NO. **312**