

PLAN SINGLE

USE 3/4" TYPE "K" COPPER PIPE

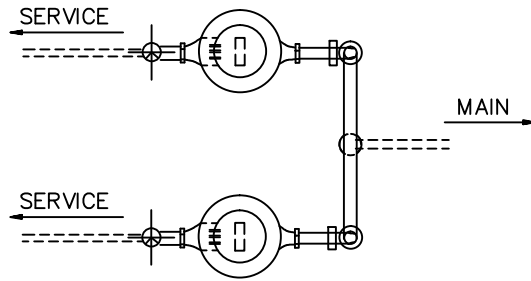

PLAN DOUBLE

USE 1" TYPE "K" COPPER PIPE

(USE FORD UV-23-42W FOR DUAL METER SETTING)

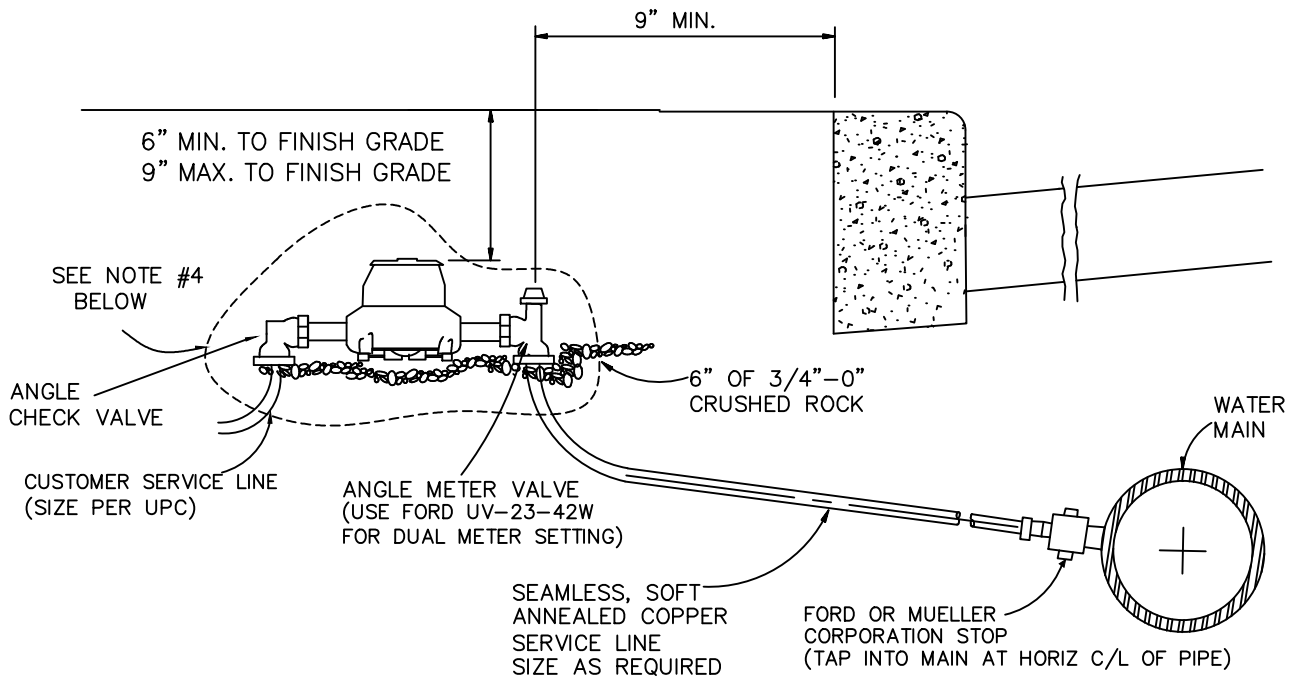

SECTION

NOTES:

1. MANUFACTURED METER SETTER MAY BE USED FOR 3/4" AND 1" SERVICES.
2. SET ANGLE METER VALVE 9" MINIMUM BEHIND CURB OR SIDEWALK.
3. FITTINGS SHALL BE FORD OR MUELLER COLD-FLARED CTS OR COMPRESSION - NO SUBSTITUTION
4. METER BOX AND METER PROVIDED BY CITY WHEN BUILDING PERMIT ISSUED.

CITY OF SANDY

**3/4" AND 1"
WATER METER SETTING
DETAIL**

DATE:
MAY 1999

DRAWING NO.
408