

COMBINED CURB RAMP

W	L	H
5'	4.36'	7/16"
5.5'	4.05'	13/32"
6'	3.73'	3/8"
6.5'	3.41'	11/32"
7'	3.10'	5/16"
7.5'	2.78'	9/32"
8'	2.46'	1/4"
8.5'	2.15'	7/32"
9'	1.83'	3/16"
9.5'	1.51'	5/32"
10'	1.20'	1/8"
10.5'	0.78'	3/32"

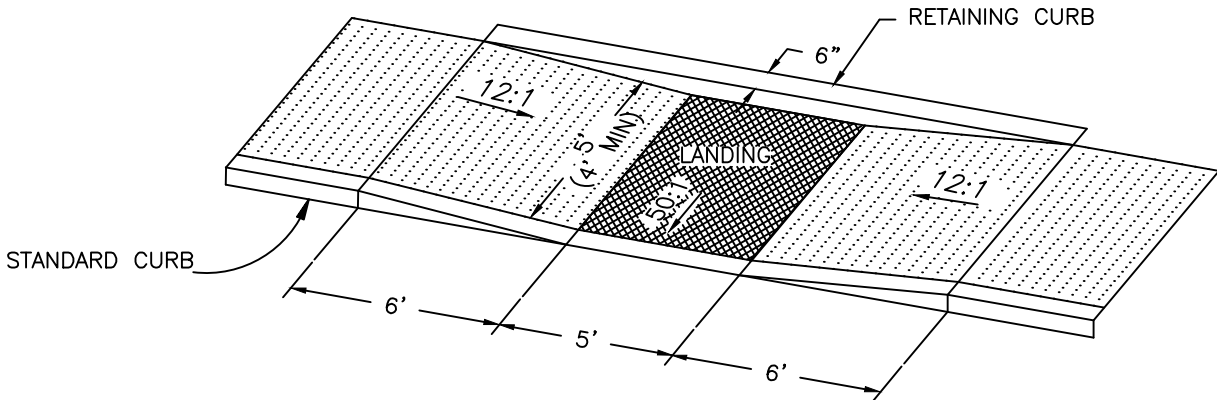

PARALLEL CURB RAMP

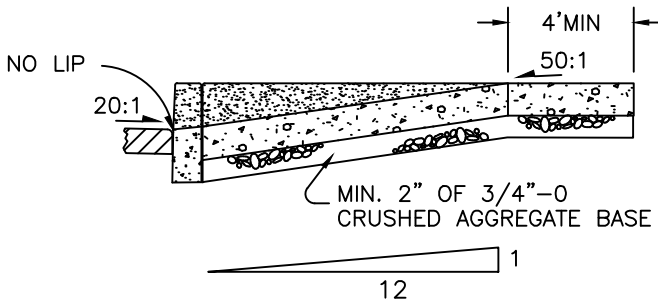

TYPICAL SECTION THROUGH COMBINED CURB RAMP

NOTES:

1. THE "AMERICANS WITH DISABILITIES ACT" (ADA) REQUIRES THAT ACCESS RAMPS TO SIDEWALKS CONFORM TO ALL FEDERAL GUIDELINES. EXCEPTIONS TO THE REQUIREMENTS IN THIS DRAWING MUST BE APPROVED BY THE ENGINEER AND MUST COMPLY WITH ADA.
2. NO ABOVE GROUND UTILITIES ARE PERMITTED WITHIN RAMP AREA.
3. LANDINGS SHALL BE PLACED AT THE TOP OF EACH RAMP. LANDING SLOPES SHALL NOT EXCEED 50:1 IN ANY DIRECTION. THE SLOPE OF THE SURFACING AT THE BOTTOM OF THE RAMP SHALL NOT EXCEED 20:1 FOR A DISTANCE OF 2' (SEE TYPICAL SECTION ABOVE).
4. MINIMUM LANDING DIMENSIONS SHALL BE 4'x 4'.
5. SEE DETAIL SANDY059.DWG FOR SURFACE TEXTURE DETAILS.
6. CONCRETE STRENGTH SHALL BE 3300 PSI.

CITY OF SANDY

**MID BLOCK SIDEWALK
ACCESS RAMPS**

DATE:
MARCH 2004

DRAWING NO.
206A