

Addendum #5

Invitation to Bid

Demolition of the Olin Bignall Aquatic Center and Old Middle School

Addendum #5- Issued November 30th, 2023

Bids Due: December 4th, 2023 at 2:00pm (Extended due date per addendum #4)

This addendum, plus attachments, is hereby made an integral part of the Contract Document to the same extent as though it was originally included therein.

Bidders must acknowledge receipt of all addenda as part of the Bid Submission Packet, Bid Form. Bids that fail to acknowledge all addenda may be considered non responsive and may be rejected.

The Invitation to Bid Addendum #5 consists of the following:

1. Clarification to Sheet C0.50 #3 under sheet notes regarding cut volume, fill volume, net cut volume, and grading.
2. Clarification to sheet C6.03 & C6.04 stockpile. All stockpiles should be removed at the completion of the project.
3. Revision to sheet C6.04 removed items not pertaining to the demolition project.
4. Clarification to sheet C6.05 #2 regarding cut volume, full volume, net cut volume.

This addendum can be found in the Project's shared Google Drive Folder linked here:

https://drive.google.com/drive/folders/1NuGhfsjDpZx-K3P0Vlse7Auxuo7T_n0x

City Project Manager:

Rochelle Anderholm-Parsch
Parks and Recreation Director
503-489-2157
randerholmparsch@ci.sandy.or.us

GENERAL NOTES

- ALL CONSTRUCTION, MATERIALS, AND WORKMANSHIP SHALL CONFORM TO THE LATEST STANDARDS AND PRACTICES OF THE CITY OF SANDY, THE OREGON STRUCTURAL SPECIALTY CODE (BUILDING CODE), OREGON PLUMBING SPECIALTY CODE (PLUMBING CODE), AND THE OREGON FIRE CODE (FIRE CODE), LATEST EDITIONS.
- THE CONTRACTOR SHALL BE RESPONSIBLE FOR COORDINATING AND SCHEDULING ALL WORK WITH THE OWNER.
- ALL PERMITS AND LICENSES NECESSARY FOR THE EXECUTION AND COMPLETION OF THE WORK SHALL BE SECURED BY THE CONTRACTOR PRIOR TO COMMENCING CONSTRUCTION.
- THE ENGINEER OR OWNER IS NOT RESPONSIBLE FOR THE SAFETY OF THE CONTRACTOR OR THE CREW. ALL O.S.H.A. REGULATIONS SHALL BE STRICTLY ADHERED TO IN THE PERFORMANCE OF THE WORK.
- HUMBER DESIGN GROUP, INC. ASSUMES NO RESPONSIBILITY FOR ANY DISCREPANCIES ENCOUNTERED BETWEEN THE CURRENT FIELD CONDITIONS AND THE INFORMATION SHOWN ON THE SURVEY MAP. THE CONTRACTOR IS RESPONSIBLE FOR REPORTING ANY DISCREPANCIES TO THE OWNER'S REPRESENTATIVE.
- WORK IN THE RIGHT-OF-WAY TO BE PERFORMED TO THE PUBLIC STANDARDS, SPECIFICATIONS, AND DETAILS OF THE JURISDICTION HAVING AUTHORITY.
- CONTRACTOR SHALL HAVE AN APPROVED SET OF PERMIT PLANS ON SITE AT ALL TIMES.
- CONTRACTOR SHALL SCHEDULE, REQUEST, AND COORDINATE ALL REQUIRED INSPECTIONS REQUIRED BY THE CONTRACT, ENGINEERS, OR PERMITTING JURISDICTIONS.

EARTHWORK, EXCAVATION, AND GRADING NOTES

- GENERAL:**
- ALL EXCAVATORS MUST COMPLY WITH THE RULES ADOPTED BY THE OREGON UTILITY NOTIFICATION CENTER, INCLUDING NOTIFICATION OF ALL OWNERS OF UNDERGROUND UTILITIES AT LEAST 48 BUSINESS DAY HOURS, BUT NOT MORE THAN 10 BUSINESS DAYS, BEFORE COMMENCING AN EXCAVATION. THOSE RULES ARE SET FORTH IN OAR 952-001-0010 THROUGH OAR 952-001-0090 AND ORS 757.541 TO 757.57. THE TELEPHONE NUMBER FOR THE OREGON UTILITY NOTIFICATION CENTER IS 503-232-1987 AND THE LOCAL "CALL 48 HOURS BEFORE YOU DIG NUMBER" IS 503-246-6699.
 - THE LOCATION OF EXISTING UNDERGROUND UTILITIES SHOWN ON THE PLANS IS FOR INFORMATION ONLY AND IS NOT GUARANTEED TO BE ACCURATE. CONTRACTOR SHALL VERIFY ELEVATIONS OF ALL UNDERGROUND UTILITIES PRIOR TO COMMENCING WITH CONSTRUCTION AND SHALL BRING ANY DISCREPANCIES TO THE ATTENTION OF HUMBER DESIGN GROUP, INC. POTHOLE ALL CROSSINGS AS NECESSARY BEFORE CONSTRUCTION TO PREVENT GRADE AND ALIGNMENT CONFLICTS
 - CONTRACTOR SHALL EXERCISE CARE IN ALL OPERATIONS TO PROTECT EXISTING UTILITIES, POLES, AND STRUCTURES. ANY DAMAGE RESULTING FROM THIS WORK MUST BE RESTORED AT THE CONTRACTOR'S EXPENSE TO THE APPROVAL OF THE OWNER'S REPRESENTATIVE.
 - CONTRACTOR SHALL REPLACE AND RESTORE AREAS NOT SCHEDULED FOR CONSTRUCTION TO THEIR ORIGINAL CONDITION AND TO THE APPROVAL OF THE OWNER'S REPRESENTATIVE.
 - ACTUAL LINES AND GRADES OF EXCAVATION SHALL BE STAKED BY QUALIFIED SURVEYOR, BASED ON DIMENSIONS AND BEARINGS AS SHOWN ON THE PLANS. CONTRACTOR SHALL RETAIN A SURVEYOR LICENSED IN OREGON.

- ADDITIONAL GEOTECHNICAL RECOMMENDATIONS:**
- ALL EARTHWORK ACTIVITIES SHALL BE COMPLETED PER RECOMMENDATIONS IN THE SOILS REPORT PREPARED BY PALI CONSULTING, INC. DATED XXXGEODATEXXX.

- TREES:**
- CONTRACTOR SHALL EXERCISE EXTREME CAUTION WHEN WORKING IN AREAS ADJACENT TO EXISTING TREES IN ORDER TO MINIMIZE DISTURBANCES TO TREE ROOTS. CONTRACTOR SHALL INSTALL TREE PROTECTION FENCING AS INDICATED ON PLANS OR AT DRIP-LINE OF EXISTING TREES IF TREE PROTECTION PLANS ARE NOT AVAILABLE.
 - NO PARKING VEHICLES UNDER TREES.

- FINAL GRADING:**
- CONSTRUCTED SURFACES SHALL MEET THE FOLLOWING SLOPE REQUIREMENTS:
 - PEDESTRIAN WALKWAYS, 2.0% MAX. CROSS SLOPE PERPENDICULAR TO THE DIRECTION OF TRAVEL.
 - ADA PARKING STALLS, 2.0% MAX. SLOPE, ANY DIRECTION
 - ADA PARKING ACCESS ISLES, 2.0% MAX. SLOPE ANY DIRECTION.
 - SIDEWALK OR RAMP LANDINGS, 2.0% MAX. SLOPE, ANY DIRECTION.
 - ASPHALT, 1.0% MIN. TO DRAIN
 - CONCRETE, 0.5% MIN. TO DRAIN
 - CONCRETE GUTTERS, 0.3% MIN. TO DRAIN

*CONTRACTOR SHALL NOTIFY HUMBER DESIGN GROUP, INC. OF ANY DISCREPANCIES ENCOUNTERED TO THE REQUIREMENTS ABOVE PRIOR TO CONSTRUCTION.

- ADJUST ALL INCIDENTAL STRUCTURES, MANHOLE LIDS, VALVE BOXES, ETC. TO FINISH GRADE.

MATERIAL NOTES

- GENERAL:**
- MATERIALS SHALL BE NEW. THE USE OF MANUFACTURERS' NAMES, MODELS, AND NUMBERS IS INTENDED TO ESTABLISH STYLE, QUALITY, APPEARANCE, AND USEFULNESS.
 - PROPOSED SUBSTITUTIONS WILL REQUIRE WRITTEN APPROVAL FROM HUMBER DESIGN GROUP, INC. PRIOR TO INSTALLATION.
 - ALL ON-SITE WATER, STORM, AND SANITARY SEWER PIPE MATERIALS AND FITTINGS SHALL CONFORM TO THE OREGON STATE PLUMBING SPECIALTY CODE, LATEST EDITION.
 - IN GROUND MATERIALS MUST ALSO BE APPROVED FOR UNDER BUILDING APPLICATIONS PER THE PLUMBING CODE IF RUNNING UNDER CANOPIES OR OTHER STRUCTURES.
- GAS:**
- CONTRACTOR SHALL CONTACT AND COORDINATE MATERIALS ASSOCIATED WITH NATURAL GAS SERVICE INSTALLATIONS DIRECTLY WITH NATURAL GAS PROVIDER.
- PRIVATE FIRE:**
- ON-SITE FIRE SERVICE 4-INCH DIAMETER AND LARGER SHALL BE EITHER DUCTILE IRON PIPE, CLASS 52, CONFORMING TO AWWA C151 OR PVC AWWA PIPE, CLASS 150, CONFORMING TO AWWA C900 UNLESS ONE MATERIAL IS SPECIFICALLY CALLED FOR ON THE PLANS. PIPES MUST BE RESTRAINED WITH APPROVED MECHANICAL RESTRAINTS OR CONCRETE THRUST BLOCKING.
 - MATERIALS RELATED TO PUBLIC CONNECTIONS, SERVICE VAULTS, FIRE HYDRANTS AND SERVICE LATERALS IN THE RIGHT-OF-WAY OR PUBLIC EASEMENTS SHALL BE INSTALLED PER THE JURISDICTION HAVING AUTHORITY.

- SANITARY:**
- ON-SITE SANITARY SEWER PIPE SHALL BE PVC PIPE CONFORMING TO ASTM D3034, SDR 35, OR APPROVED SUBSTITUTE.

- STORM:**
- ON-SITE STORM SEWER PIPE SHALL BE PVC PIPE CONFORMING TO ASTM D3034 SDR 35, OR HDPE PIPE (ADS 'N-12' OR APPROVED EQUAL) CONFORMING TO AASHTO M252 W/WATER TIGHT JOINTS, OR APPROVED SUBSTITUTIONS.

- ON-SITE STORM SEWER PIPE WITH LESS THAN 2- FEET OF COVER SHALL BE HDPE PIPE.

MATERIAL NOTES

- STORM:**
- ON-SITE AREA DRAINS SHALL BE MANUFACTURED BY LYNCH CO., INC. OR APPROVED EQUAL.
- WATER:**
- ON-SITE WATER SERVICES 4-INCH DIAMETER AND LARGER SHALL BE EITHER DUCTILE IRON PIPE, CLASS 52, CONFORMING TO AWWA C151 OR PVC AWWA PIPE, CLASS 150, CONFORMING TO AWWA C900 UNLESS ONE MATERIAL IS SPECIFICALLY CALLED FOR ON THE PLANS. PIPES MUST BE RESTRAINED WITH APPROVED MECHANICAL RESTRAINTS OR CONCRETE THRUST BLOCKING.
 - ON-SITE WATER SERVICE SMALLER THAN 4-INCH DIAMETER SHALL BE COPPER TUBING CONFORMING TO ASTM B88, SILVER SOLDER, OR APPROVED SUBSTITUTIONS
 - MATERIALS RELATED TO PUBLIC CONNECTIONS, WATER METERS, AND BACK FLOW DEVICES AND ASSOCIATED SERVICE LATERALS IN THE RIGHT-OF-WAY OR PUBLIC EASEMENTS SHALL BE INSTALLED PER THE JURISDICTION HAVING AUTHORITY.

UTILITY NOTES

- GENERAL:**
- VERIFY ELEVATIONS OF ALL UNDERGROUND UTILITIES PRIOR TO COMMENCING WITH CONSTRUCTION AND SHALL BRING ANY DISCREPANCIES TO THE ATTENTION OF HUMBER DESIGN GROUP, INC. POTHOLE ALL CROSSINGS AS NECESSARY BEFORE CONSTRUCTION TO PREVENT GRADE AND ALIGNMENT CONFLICTS
 - CONTRACTOR TO ADJUST ALL EXISTING OR NEW FLEXIBLE UTILITIES (WATER, GAS, TV, TELEPHONE, ELECTRICAL, ETC.) TO CLEAR ANY EXISTING OR NEW GRAVITY DRAIN UTILITIES (STORM DRAIN, SANITARY SEWER, ETC.) IF CONFLICT OCCURS.
 - CONNECTIONS TO EXISTING UTILITIES SHALL CONFORM WITH THE REQUIREMENTS OF THE JURISDICTION HAVING AUTHORITY

- TRENCHING:**
- ALL PRIVATE TRENCH BACKFILL SHALL BE AS SHOWN ON THE PIPE BEDDING AND BACKFILL DETAIL. FLOODING OR JETTING THE BACKFILLED TRENCHES WITH WATER IS NOT PERMITTED.
 - TRENCHING IN THE PUBLIC RIGHT-OF-WAY SHALL BE PER THE JURISDICTION HAVING AUTHORITY.

- SANITARY/SEWER:**
- BEGIN LAYING STORM AND SANITARY PIPE AT THE LOW POINT OF THE SYSTEM TRUE TO GRADE AND ALIGNMENT INDICATED WITH UNBROKEN CONTINUITY OF INVERT. ESTABLISH LINE AND GRADE FOR THE STORM PIPE BY THE USE OF A LASER.
 - EXISTING STORM AND SANITARY LATERALS TO BE UTILIZED FOR NEW SYSTEM MUST BE VIDEO INSPECTED WITH CITY INSPECTOR PRESENT PRIOR TO CONNECTION.
 - ALL NEW DRYWELLS MUST BE ACCESSIBLE PER OREGON DEPARTMENT OF ENVIRONMENTAL QUALITY REQUIREMENTS.
 - CONTRACTOR SHALL VACUUM OUT ALL TRAPPED INLETS, MANHOLES, AND DRYWELLS AT END OF PROJECT.
 - CONTRACTOR SHALL PREVENT SEDIMENTS FROM ENTERING THE STORM AND SANITARY DRAINAGE SYSTEM.

- WATER/FIRE:**
- ALL WATER AND FIRE PROTECTION PIPE SHALL HAVE MINIMUM 36-INCH COVER TO FINISHED GRADE.

- ALL WATER AND FIRE LINES SHALL BE THOROUGHLY FLUSHED, CHLORINATED AND TESTED IN ACCORDANCE WITH THE OREGON STATE HEALTH DEPARTMENT PRIOR TO ANY METER HOOK-UP SERVICE.
- CONTRACTOR SHALL MAINTAIN A MINIMUM 10-FOOT HORIZONTAL AND 18-INCH VERTICAL SEPARATION BETWEEN ALL EXISTING AND PROPOSED WATER AND SEWER LINES.
- FOR CROSSINGS OF WATER LINES AND SANITARY SEWER LINES, THE OREGON STATE HEALTH DEPARTMENT CRITERIA SHALL APPLY.
- DOMESTIC WATER SERVICE BACKFLOW ASSEMBLY SHALL BE INSTALLED PRIOR TO ANY BRANCHES IN THE DOMESTIC PLUMBING SYSTEM.
- BACKFLOW ASSEMBLY(S) TO BE INSTALLED AT THE POINT WHERE THE WATER SERVICE ENTERS THE PROPERTY. IF APPROVED TO BE INSTALLED INSIDE OF BUILDING, ASSEMBLY(S) MUST BE INSTALLED AT THE POINT WHERE SERVICE ENTERS, BETWEEN 1 AND 5- FEET ABOVE THE FLOOR.
- IF THE REDUCE PRESSURE (RP) BACKFLOW ASSEMBLY IS REQUIRED IT MUST BE INSTALLED AT LEAST 12-INCHES ABOVE FINISHED GRADE. RP DEVICE IS REQUIRED IF PROJECT IS HARVESTING RAINWATER.
- LANDSCAPE IRRIGATION POINT-OF-CONNECTION TO DOMESTIC WATER SYSTEM MUST OCCUR DOWNSTREAM OF THE DOMESTIC WATER SERVICE BACKFLOW PROTECTION.

ABBREVIATIONS

AD	AREA DRAIN	NO	NUMBER
A-	ARCHITECTURAL	NW	NORTHWEST NATURAL
BES	BUREAU OF ENVIRONMENTAL SERVICES	OWS	OIL WATER SEPARATOR
BFZ	BUILDING FRONTAGE ZONE	OD	OVERFLOW DRAIN
BM	BENCHMARK	OF	OUTFALL
BOT	BOTTOM	P-	PLUMBING
BOVA	BLOW OFF VALVE ASSEMBLY	PC	POINT OF CURVATURE
BS	BOTTOM OF STAIR	PCC	POINT OF COMPOUND CURVATURE
BW	BOTTOM OF WALL	PERF	PERFORATED
BWV	BACKWATER VALVE	PGE	PORTLAND GENERAL ELECTRIC
CB	CATCH BASIN	PI RPBA	PREMISE ISOLATION REDUCED PRESSURE BACKFLOW ASSEMBLY
CJ	CONTRACTION JOINT	PL	PROPERTY LINE
CL	CENTERLINE	POC	POINT OF CONNECTION
CO	CLEANOUT TO GRADE	PPL	PACIFIC POWER
COS	CITY OF SANDY	PRC	POINT OF REVERSE CURVATURE
CT	CURB TAPER	PSI	POUNDS PER SQUARE INCH
CCDA	DOUBLE CHECK DETECTOR ASSEMBLY	PT	POINT OF TANGENCY
DCVA	DOUBLE CHECK VALVE ASSEMBLY	PUE	PUBLIC UTILITY EASEMENT
DFU	DRAINAGE FIXTURE UNIT	PVC	POLYVINYL CHLORIDE
DIP	DUCTILE IRON PIPE	PWB	PORTLAND WATER BUREAU
DS	DOWNSPOUT	PWR	POWER
DTL	DETAIL	PZ	PEDESTRIAN ZONE
DW	DRYWELL	R	RADIUS
DWG	DRAWING	ROW	RIGHT OF WAY
E	ELECTRICAL	RP	RADIUS POINT
EG	EXISTING GRADE	RPBA	REDUCED PRESSURE BACKFLOW ASSEMBLY
EJ	EXPANSION JOINT	RT	RIGHT
ESMT	EASEMENT	RW	RETAINING WALL
F	FIRE	S	SLOPE
FC	FLUSH CURB	S-	STRUCTURAL
FD	FOUNDATION DRAIN	SC	SAWCUT
FDC	FIRE DEPARTMENT CONNECTION	SD	STORM SEWER
FF	FINISH FLOOR ELEVATION	SDCO	STORM CLEANOUT TO GRADE
FG	FINISHED GRADE	SDPS	STORM PUMP STATION
FH	FIRE HYDRANT	SEDMH	SEDIMENT MANHOLE
FL	FLOW LINE	SHT	SHEET
FLG	FLANGE	SP	SUMP PUMP
FM	FORCE MAIN	SS	SANITARY SEWER
FP	FIRE PROTECTION	SSAD	SANITARY AREA DRAIN
FPBH	FROST PROOF HOSE BIBB	SSCO	SANITARY CLEANOUT TO GRADE
FZ	FURNISHING ZONE	SSPS	SANITARY PUMP STATION
G	GUTTER	STD	STANDARD
G(E)	GUTTER EXISTING	SWP	STORMWATER PLANTER
OB	GRADE BREAK	TC	TOP OF CURB
GEN	GENERATOR	TC(E)	TOP OF CURB EXISTING
GI	GREASE INTERCEPTOR	TD	TRENCH DRAIN
GL	GRID LINE	TJ	TOOL JOINT
GM	GAS METER	TP	TOP OF PAVEMENT
GV	GATE VALVE	TP(E)	TOP OF PAVEMENT EXISTING
HP	HIGH POINT	TS	TOP OF STAIR
HR	HANDRAIL	TW	TOP OF WALL
IE	INVERT ELEVATION	TYP	TYPICAL
IP	IRON PIPE	VB	VALVE BOX
IR	IRON ROD	VIF	VERIFY IN FIELD
IRR	IRRIGATION	W	WATER
IS	INLET STRUCTURE	WEIR	WEIR
L-	LANDSCAPE	WM	WATER METER
LF	LINEAL FEET	WQCB	WATER QUALITY CATCH BASIN
LP	LOW POINT	WS	WHEEL STOP
LT	LEFT	WSFU	WATER SYSTEM FIXTURE UNIT
MC	MOUNTABLE CURB	WV	WATER VALVE
MH	MANHOLE	XMFR	TRANSFORMER
MH-X	SAMPLING MANHOLE	YPC	YELLOW PLASTIC CAP
(SAMPLING)			
MIN	MINIMUM		
MJ	MECHANICAL JOINT		
MON	MONUMENT		

LEGEND

EXISTING	PROPOSED	DESCRIPTION
		MANHOLE
		AREA DRAIN
		WATER METER
		UTILITY POLE
		TREE
---	---	PROPERTY LINE
---	---	CENTERLINE
---	107	CONTOUR
---	-----	SAWCUT LINE
====	====	EDGE OF PAVEMENT
---	---	CURB
--- X" SD ---	--- X" SD ---	STORM DRAIN
--- X" SS ---	---	SANITARY SEWER
--- X" W ---	--- X" W ---	WATER
--- OHP ---	---	OVERHEAD POWER
--- PWR ---	---	POWER

OWNER/ENGINEER

DEVELOPER: CITY OF SANDY 38438 PIONEER BLVD SANDY, OR 97055 (503)489-2157 CONTACT: ROCHELLE ANDERHOLM-PARSONS	CIVIL ENGINEER: HUMBER DESIGN GROUP, INC. 110 SE MAIN ST, SUITE 200 PORTLAND, OR 97214 (503)946-6690 CONTACT: ALLEN SCHMITZ, PE
---	---

SURVEY

SURVEY PROVIDED BY 45TH PARALLEL GEOMATICS, LLC, DATED JANUARY 31, 2023.

45TH PARALLEL GEOMATICS, LLC
408 CASCADE AVE #1863,
HOOD RIVER, OREGON 97031
CONTACT: SAMANTHA TANNER

SHEET INDEX

- C0.00 CIVIL NOTES
- C0.50 DEMOLITION PLAN
- C0.51 ENLARGED DEMOLITION PLAN
- C1.00 LAYOUT AND PAVING PLAN
- C2.00 GRADING PLAN
- C3.00 UTILITY PLAN
- C4.00 CIVIL DETAILS

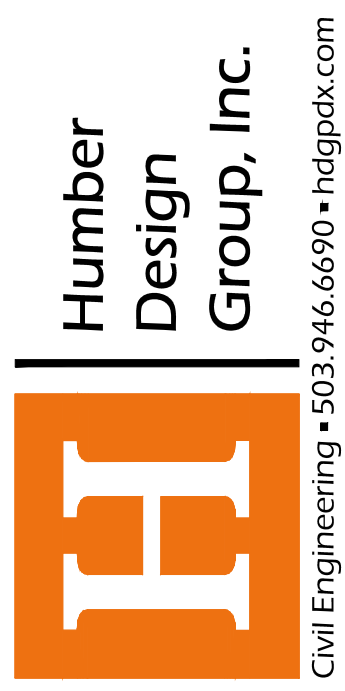

COVER SHEET
 SANDY COMMUNITY BUILDING DEMO
 CITY OF SANDY
 39250 PIONEER BOULEVARD SANDY OR 97055

REV	DATE	DESCRIPTION	BY

SHEET NO.

C0.00

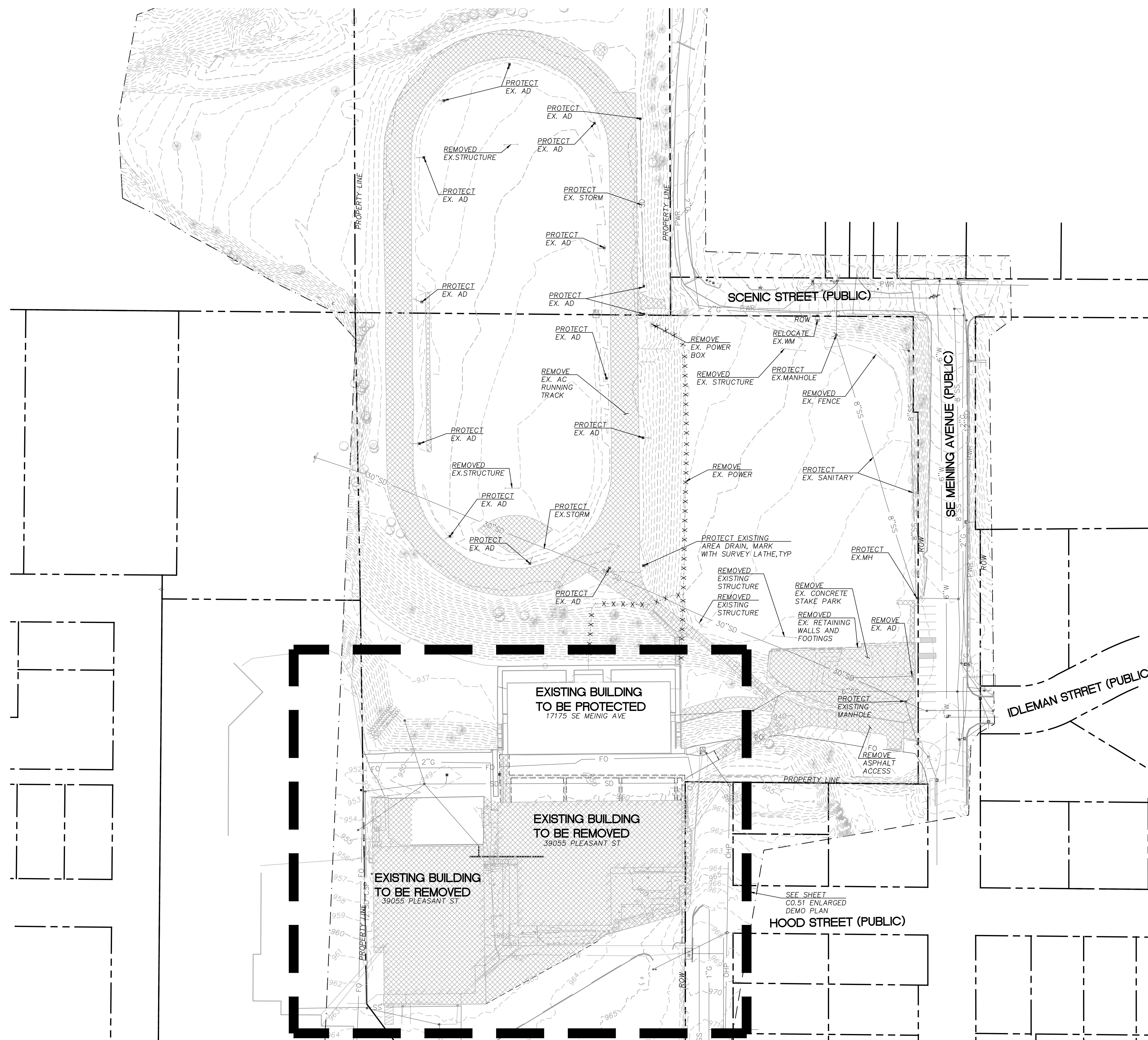

SHEET LEGEND		
ITEM	DESCRIPTION	DETAILS
	DEMOLISH ASPHALT, CONCRETE, AND STRUCTURE	
	EXISTING CONTOUR	

SHEET NOTES		
1.	SEE SEPARATE 1200C PLANS FOR EROSION CONTROL.	
2.	SEE SEPARATE PUBLIC WORK PERMIT PLANS FOR ALL WORK IN PUBLIC RIGHT OF WAY.	
3.	CUT VOLUME = 7,776 CY, FILL VOLUME = 1,419 CY NET CUT VOLUME = 6,357 CY - VOLUMES INCLUDE REMOVAL OF TRACK, SKATE PARK, AND ACCESS ROAD FROM PARK AREA. ALSO INCLUDE REMOVAL OF BUILDING AND FINAL GRADING. CONTRACTOR TO CONFIRM QUANTITIES. NO FINAL OR MASS GRADING IS NEEDED FOR THE PARK PROJECT.	

REV	DATE	DESCRIPTION	BY
1	11/21/2023	ADDENDUM 3	MCS
2	11/29/2023	ADDENDUM 5	MCS

PROJECT NO.:	
DRAWN BY:	
DESIGN BY:	
REVIEWED BY:	
DATE:	

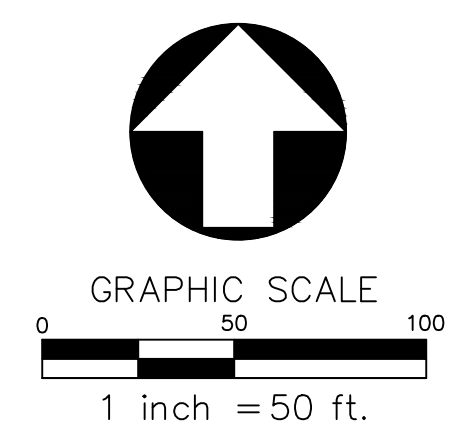

DEMOLITION PLAN
 SCALE: 1"=50'

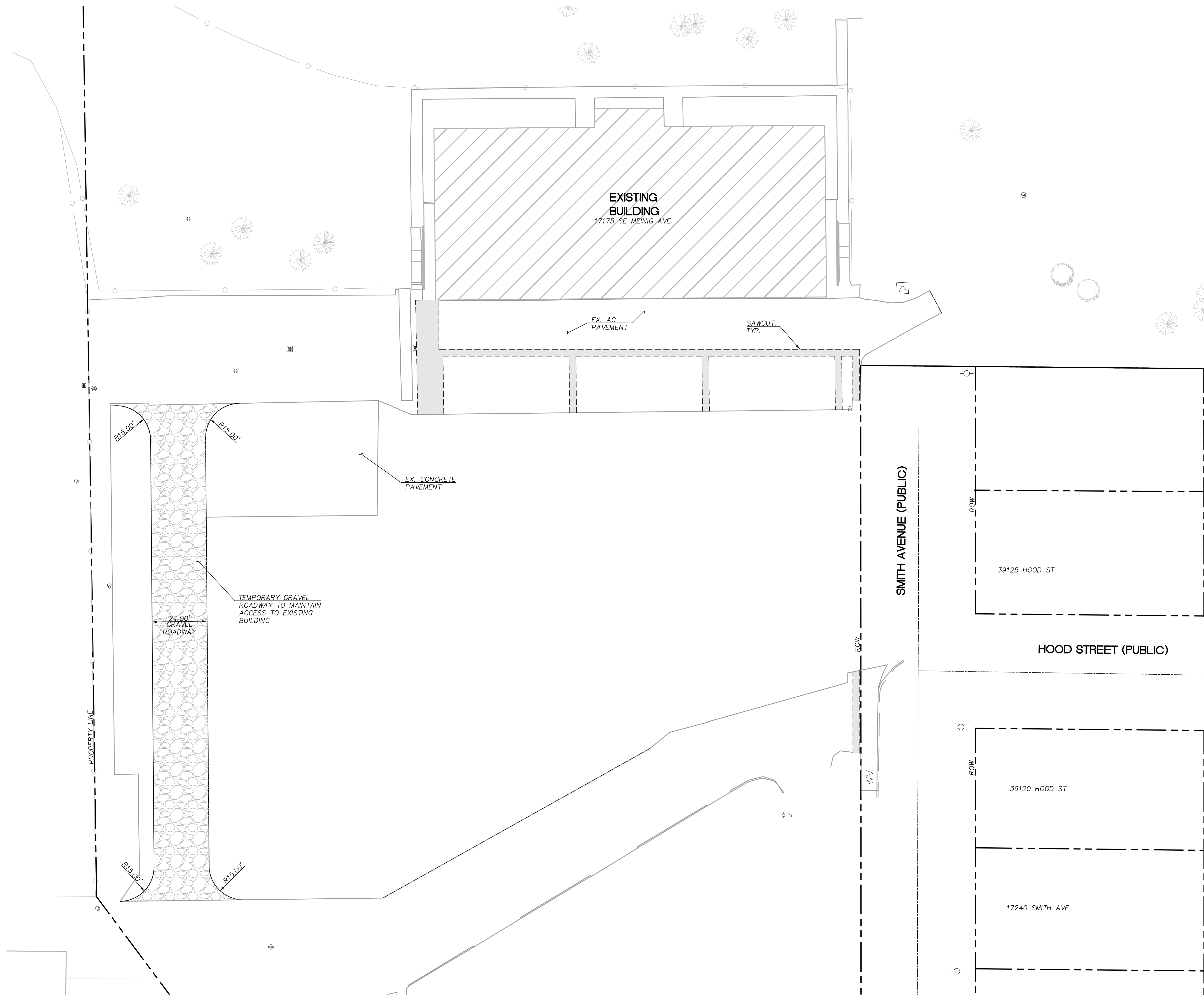

SHEET LEGEND		
ITEM	DESCRIPTION	DETAILS
	PRIVATE ASPHALT PAVING	2 C4.00
	GRAVEL ROADWAY	1 C4.00
	PRIVATE CONCRETE PAVING	3 C4.00
	SAWCUT	
	EDGE OF PAVEMENT	

Humber Design Group, Inc.

Civil Engineering • 503.946.6690 • hdbgdx.com

LAYOUT AND PAVING PLAN

SANDY COMMUNITY BUILDING DEMO

CITY OF SANDY
39250 PIONEER BOULEVARD SANDY OR 97055

REV	DATE	DESCRIPTION	BY

PROJECT NO.:
DRAWN BY:
DESIGN BY:
REVIEWED BY:
DATE:

SHEET NO.
C1.00

LAYOUT AND PAVING PLAN
SCALE: 1"=20'

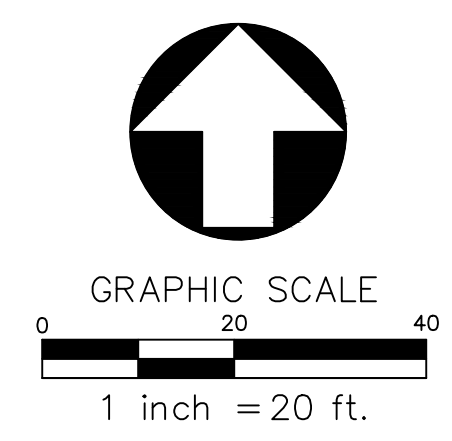

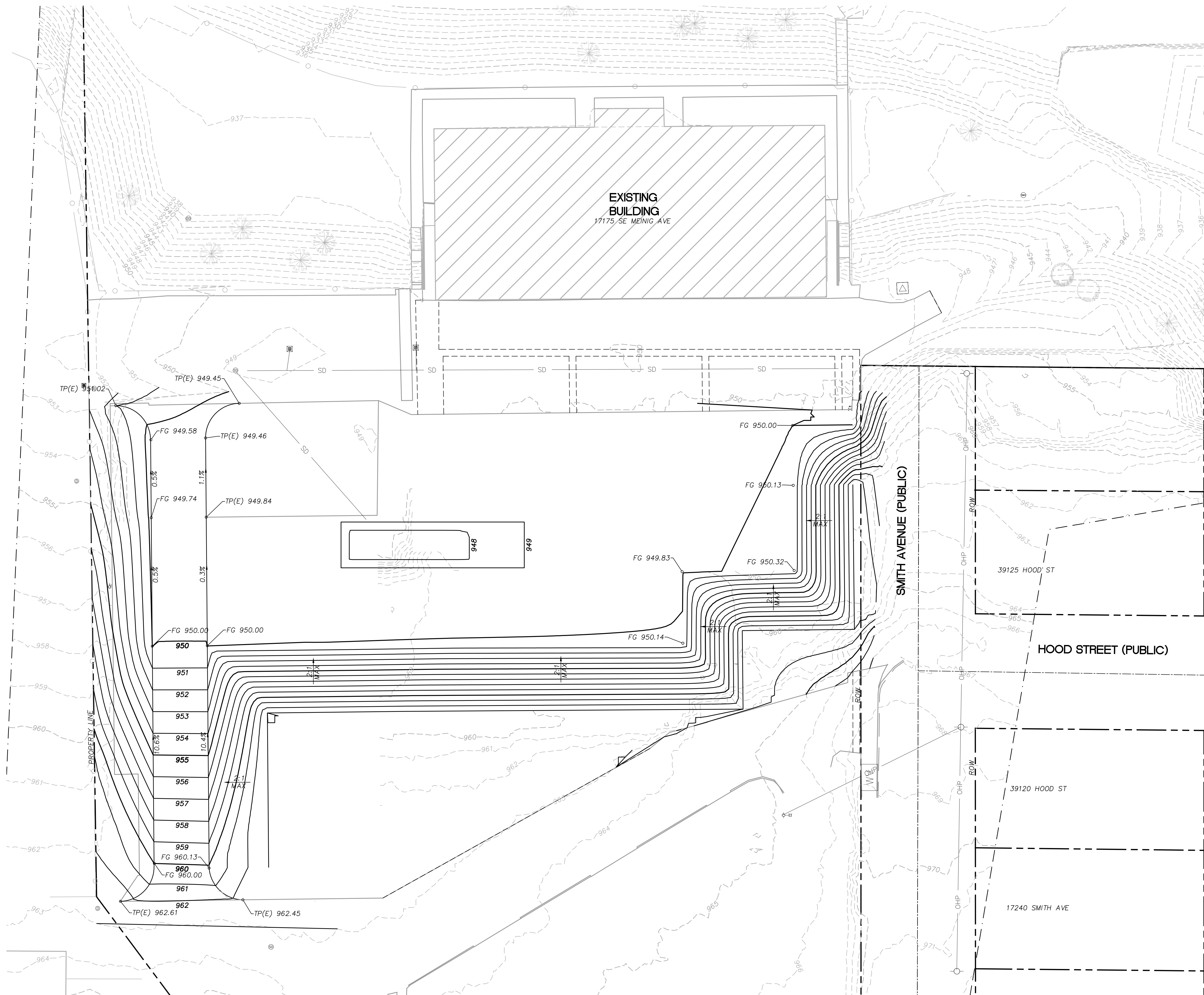

SHEET LEGEND		
ITEM	DESCRIPTION	DETAILS
- - - 950 - - -	EXISTING CONTOUR	
— 950 —	PROPOSED CONTOUR	
- - -	SAWCUT	
TC XXX.XX	GRADE AT TOP OF CURB	
FG XXX.XX	FINISH GRADE	
TP XXX.XX	GRADE AT TOP OF PAVEMENT	
FFE XXX.XX	FINISH FLOOR ELEVATION	
BW XXX.XX	GRADE AT BOTTOM OF WALL	
TW XXX.XX	GRADE AT TOP OF WALL	
(E)	EXISTING	
↘ X.XX%	SLOPE ARROW	
-GB-	GRADE BREAK	

GRADING PLAN
SCALE: 1"=20'

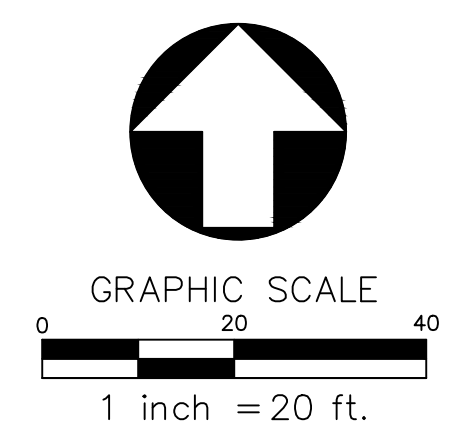

REV	DATE	DESCRIPTION	BY

PROJECT NO.:	
DRAWN BY:	
DESIGN BY:	
REVIEWED BY:	
DATE:	

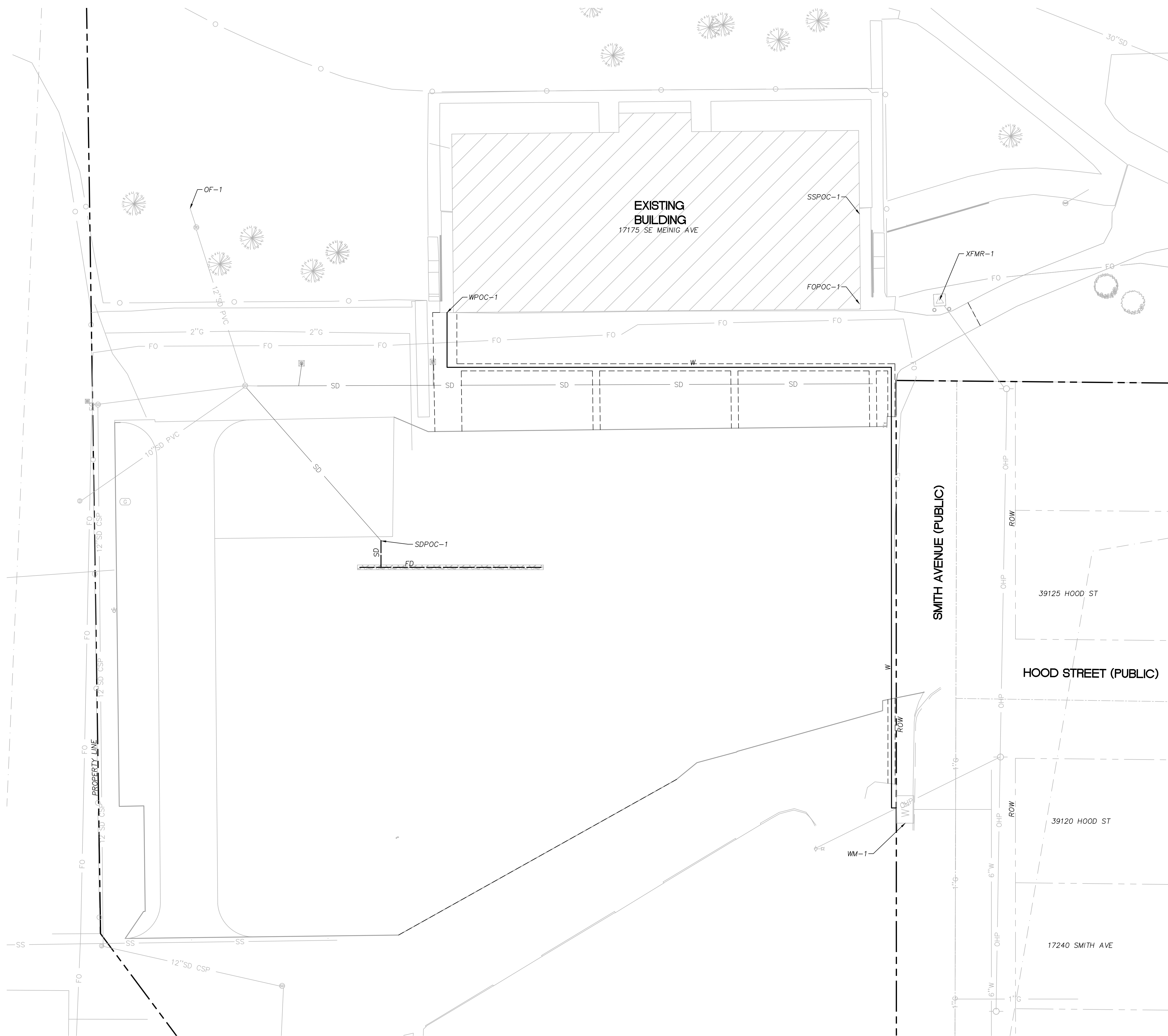

UTILITY PLAN
SCALE: 1"=20'

SHEET LEGEND		
ITEM	DESCRIPTION	DETAILS
W	WATER	
SD	STORM	

WATER SCHEDULE		
ITEM	DESCRIPTION	REFERENCE
WPOC-1	WATER POINT OF CONNECTION SIZE=X", IE=XXX	
WM-1	EXISTING WATER METER	

POWER, FIBER, AND GAS SCHEDULE		
ITEM	DESCRIPTION	REFERENCE
XFMR-1	EXISTING TRANSFORMER	
FOPOC	FIBER OPTIC POINT OF CONNECTION, CONFIRM WITH SANDY NET	

SANITARY SCHEDULE		
ITEM	DESCRIPTION	REFERENCE
SSPOC-1	SANITARY SEWER POINT OF CONNECTION SIZE=6", IE=UNKNOWN	

STORMWATER SCHEDULE		
ITEM	DESCRIPTION	REFERENCE
OF-1	OUTFALL, SIZE=12", LOCATION AND INVERT UNKNOWN	
FD	FRENCH DRAIN, 76LF FRENCH DRAIN PER DETAIL	DTL. 5/SHT. C4.00
SDPOC-1	STORM POINT OF CONNECTION, CONNECT WITH EXISTING STORM PIPE. SIZE= TBD, IE=TBD	

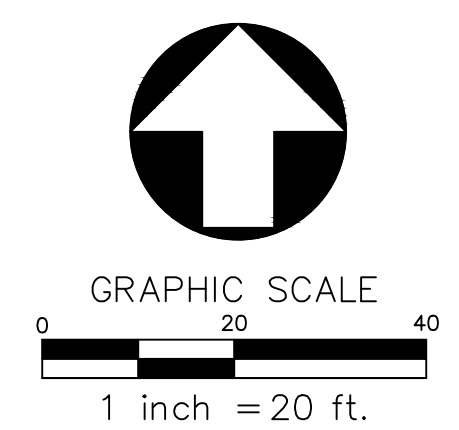

Humber
Design
Group, Inc.



Civil Engineering • 503.946.6690 • hdbgdx.com

UTILITY PLAN

SANDY COMMUNITY BUILDING DEMO
CITY OF SANDY
39250 PIONEER BOULEVARD SANDY OR 97055

REV	DATE	DESCRIPTION	BY

PROJECT NO.:
DRAWN BY:
DESIGN BY:
REVIEWED BY:
DATE:

SHEET NO.
C3.00

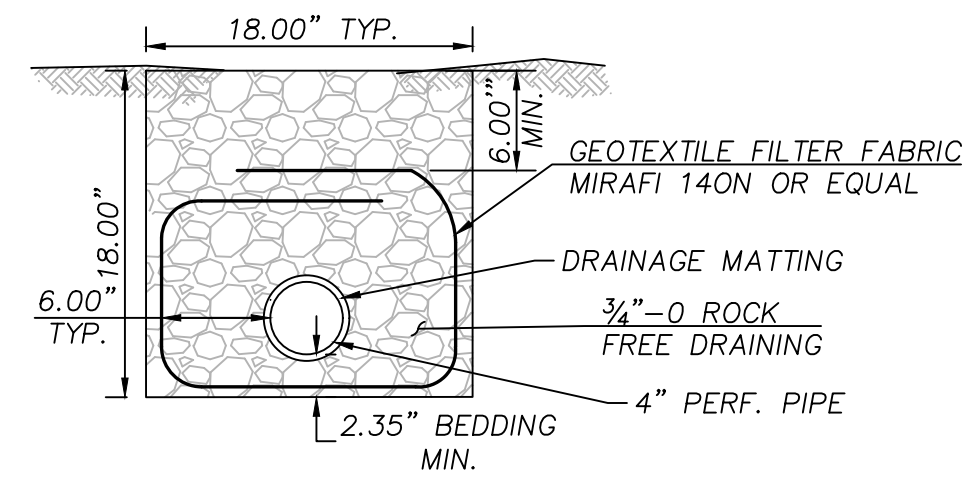

5 FRENCH DRAIN
NTS

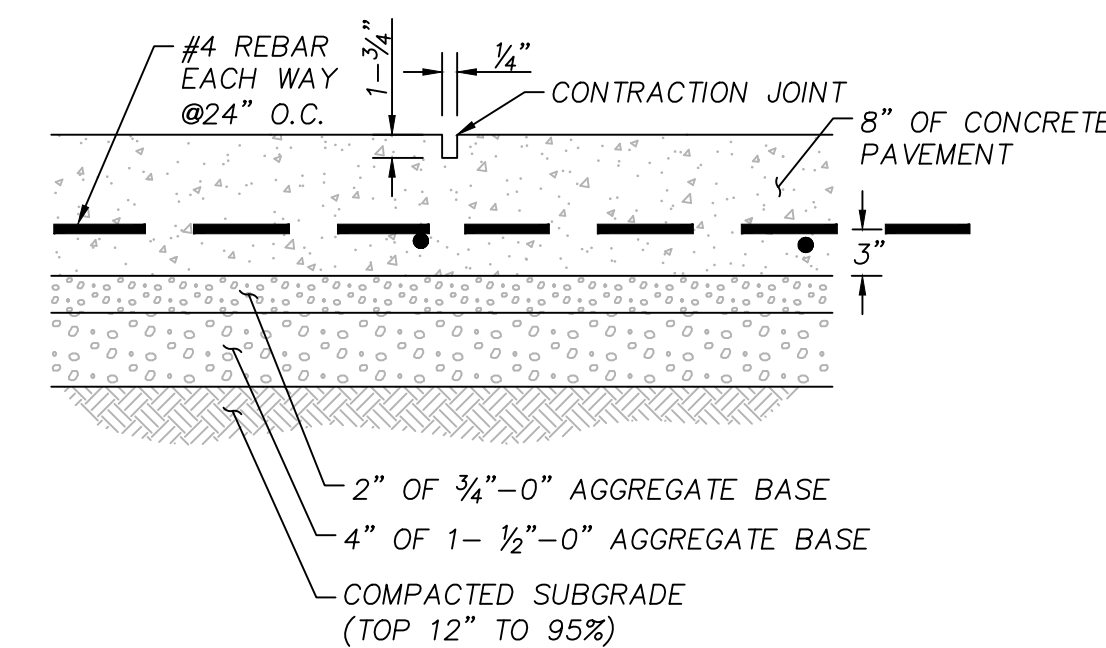

- NOTES:**
1. CONCRETE SHALL BE 4000 PSI, SLUMP RANGE 3" TO 5"
 2. INSTALL CONTRACTION JOINTS AT 10' O.C. BOTH DIRECTIONS
 3. REBAR TO HAVE A TENSILE YIELD STRENGTH OF 60,000 PSI
 4. AGGREGATE BASE AND THE UPPER 12" OF THE SUBGRADE SHALL BE COMPACTED TO 95% OF THE MAXIMUM DRY DENSITY DETERMINED IN ACCORDANCE WITH ASTM D1557

3 CONCRETE PAVEMENT
NTS

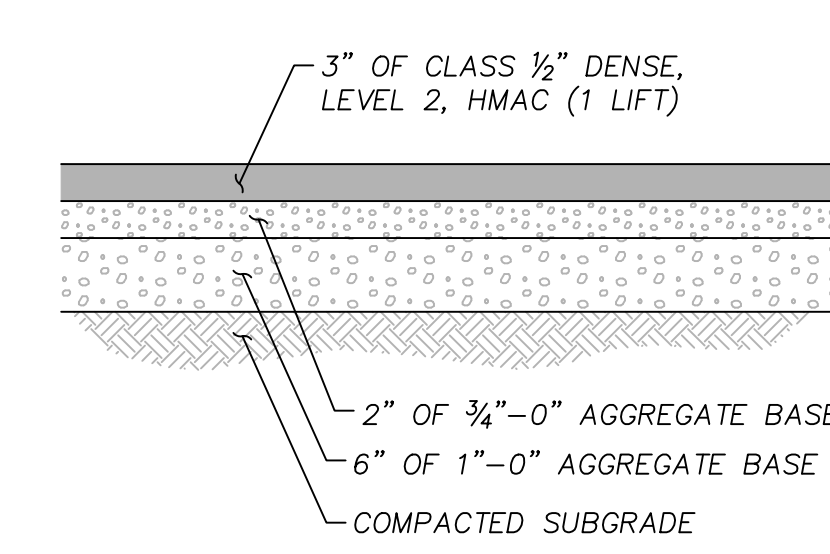

- NOTES:**
1. AGGREGATE BASE AND THE UPPER 12" OF THE SUBGRADE SHALL BE COMPACTED TO 95% OF THE MAXIMUM DRY DENSITY DETERMINED IN ACCORDANCE WITH ASTM D1557.
 2. AC PAVEMENT SHALL BE COMPACTED TO 91% OF THE RICE DENSITY OF THE MIX.

2 ASPHALT PAVEMENT
NTS

ASSUMED GRAVEL SECTION.
SECTION TO BE VERIFIED
BY GEOTECHNICAL
ENGINEER AND DESIGN
UPDATED ACCORDINGLY.

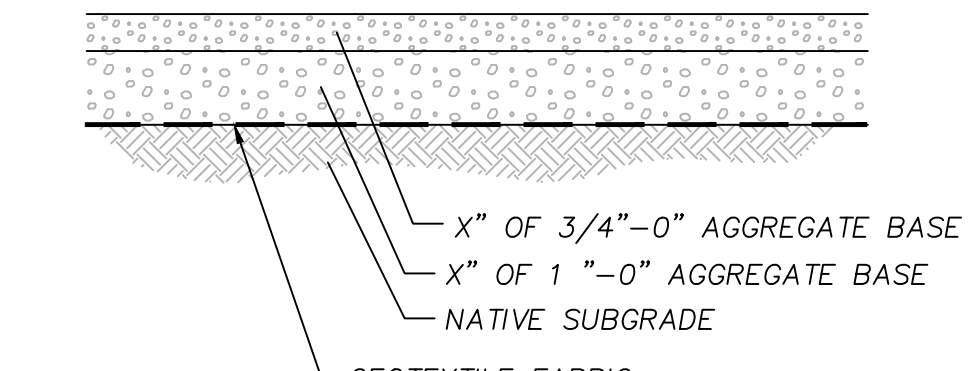

- NOTES:**
1. AGGREGATE BASE SHALL BE COMPACTED TO 92% OF THE MAXIMUM DRY DENSITY DETERMINED IN ACCORDANCE WITH ASTM D1557.
 2. WOVEN POLYPROPYLENE GEOTEXTILE WITH GRAB TENSILE STRENGTH (ASTM D4632) OF AT LEAST 300 POUNDS AND PUNCTURE STRENGTH (ASTM D4833) OF AT LEAST 110 POUNDS.

1 GRAVEL PAVEMENT
NTS

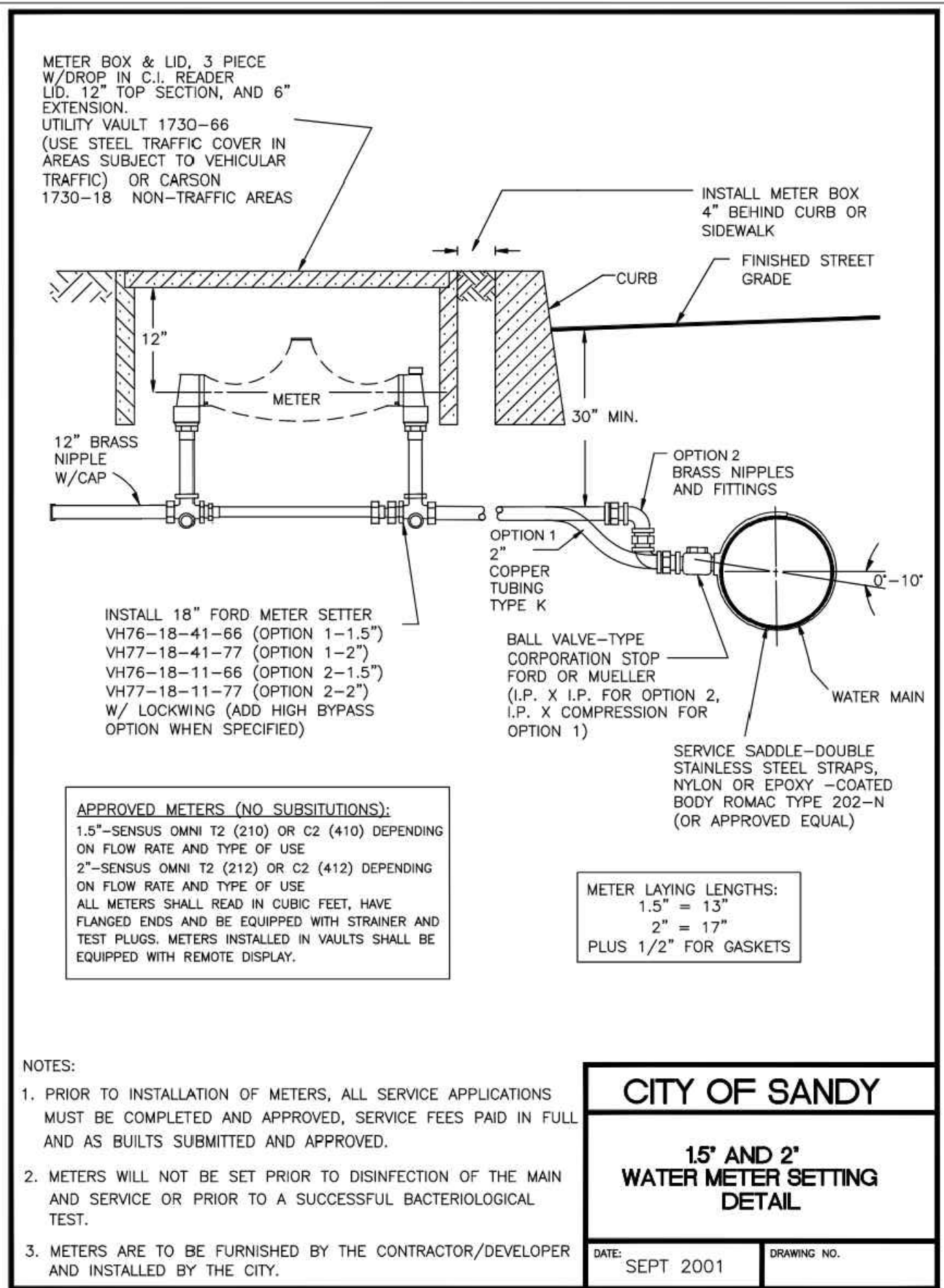

4 WATER METER
NTS

CITY OF SANDY
15" AND 2" WATER METER SETTING DETAIL
DATE: SEPT 2001 DRAWING NO.

- NOTES:**
1. PRIOR TO INSTALLATION OF METERS, ALL SERVICE APPLICATIONS MUST BE COMPLETED AND APPROVED, SERVICE FEES PAID IN FULL AND AS BUILTS SUBMITTED AND APPROVED.
 2. METERS WILL NOT BE SET PRIOR TO DISINFECTION OF THE MAIN AND SERVICE OR PRIOR TO A SUCCESSFUL BACTERIOLOGICAL TEST.
 3. METERS ARE TO BE FURNISHED BY THE CONTRACTOR/DEVELOPER AND INSTALLED BY THE CITY.

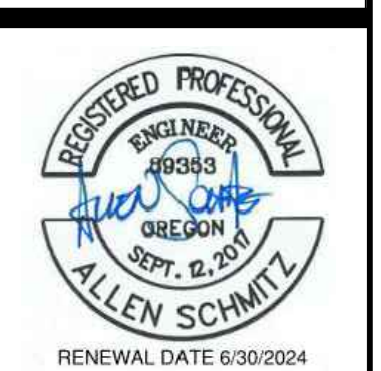

REV	DATE	DESCRIPTION	BY
1	11/21/2023	ADDENDUM 3	MCS

EROSION AND SEDIMENT CONTROL PLANS

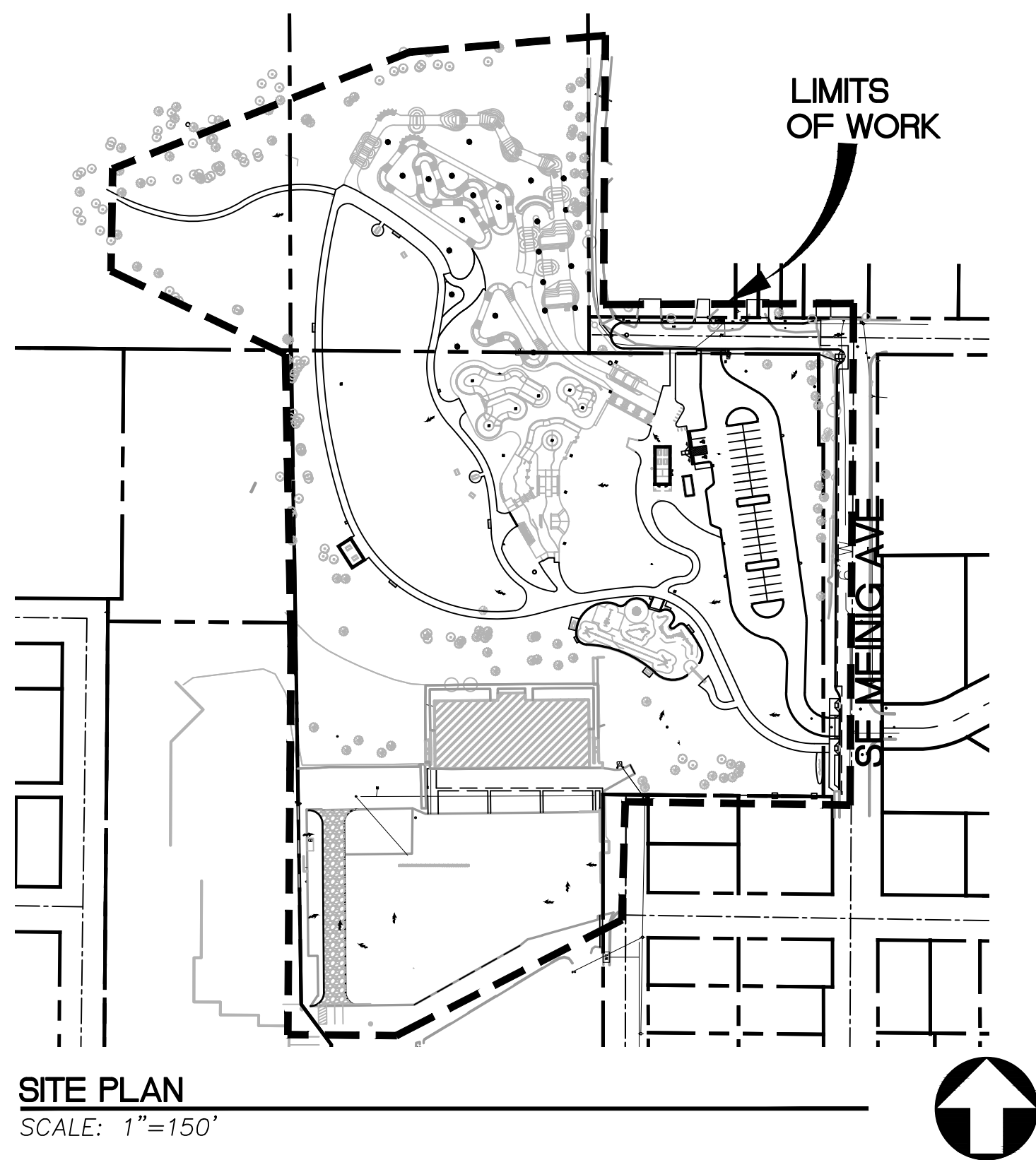

SITE PLAN
SCALE: 1"=150'

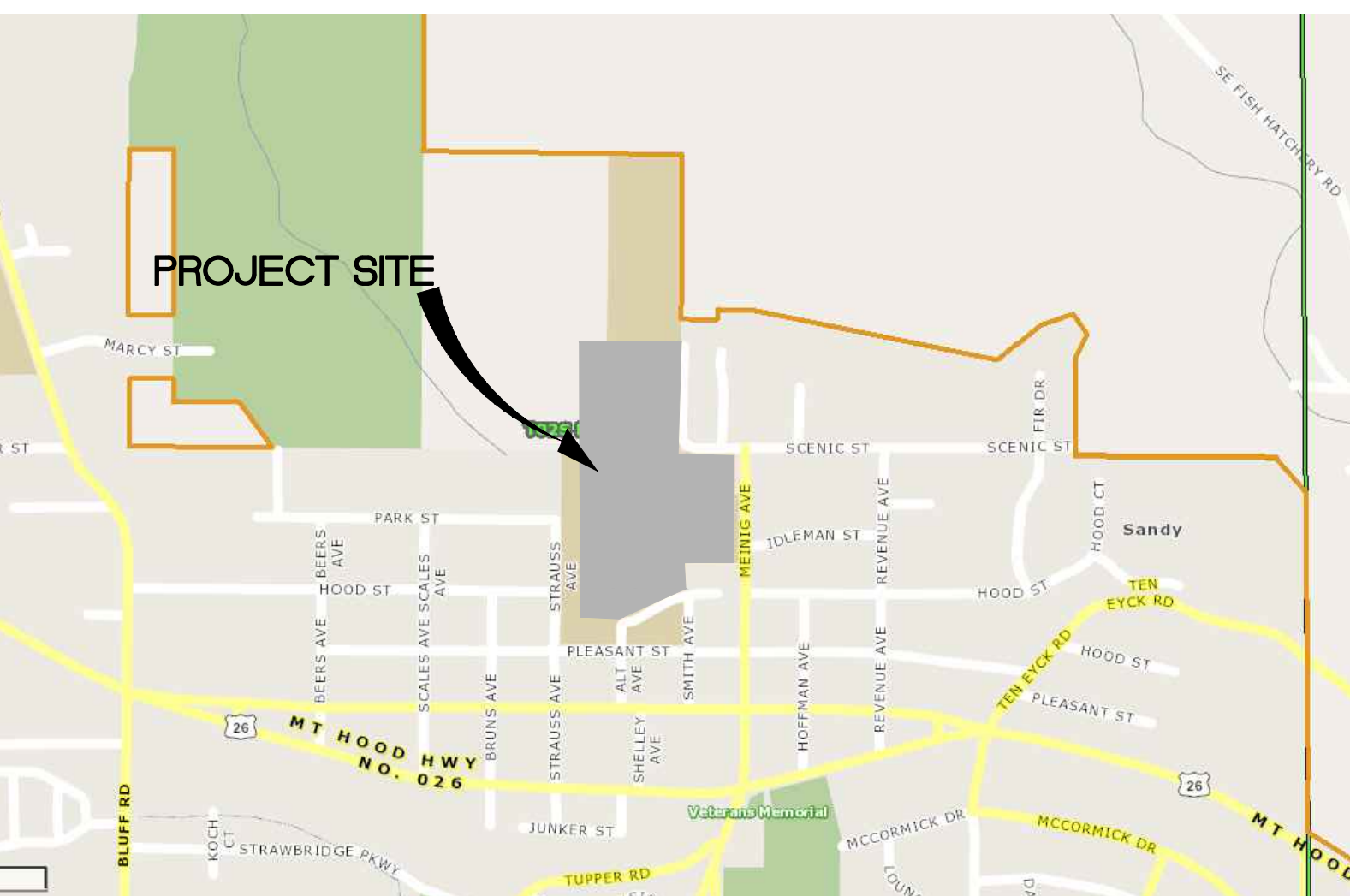

VICINITY MAP
SCALE: 1"=600'

PROJECT LOCATION:

THE SITE IS LOCATED IN THE CITY OF SANDY, CLACKAMAS COUNTY, OREGON. THE SITE IS BOUNDED BY SCENIC STREET ON THE NORTH, SE MEING AVENUE TO THE EAST.

PROPERTY DESCRIPTION:

WITHIN THE TAX LOTS 101, 200, AND 300, SITUATED IN SECTION 18BA AND 18BD, TOWNSHIP 2 SOUTH, RANGE 4 EAST, WILLAMETTE MERIDIAN, CITY OF SANDY, CLACKAMAS COUNTY, OREGON

LAT. 45.40008
LONG. -122.2606

OWNER/DEVELOPER

CITY OF SANDY
39250 PIONEER BLVD
SANDY, OR 97055
(503)688-5569
CONTACT: ROCHELLE ANDERHOLM-PARSONS

CIVIL ENGINEER

HUMBER DESIGN GROUP, INC.
110 SE MAIN STREET, SUITE 200
PORTLAND, OR 97214
(503)946-5358
CONTACT: ALLEN SCHMITZ, PE

ARCHITECT

LANGO HANSEN LANDSCAPE ARCHITECTS
1100 NW GLISAN #3A
PORTLAND, OR 97209
(503)553-9242
CONTACT: BRIAN MARTIN

SURVEYOR

45TH PARALLEL GEOMATICS, LLC
408 CASCADE AVE #1863
HOOD RIVER, OREGON 97031
CONTACT: SAMANTHA TANNER

NARRATIVE DESCRIPTIONS

EXISTING SITE CONDITIONS

(2) TWO STORY BUILDINGS WITH ASPHALT AND CONCRETE PAVEMENT.

GRASS GROUND WITH ASPHALT AND CONCRETE PAVEMENT.

DEVELOPED CONDITIONS

TEMPORARY GRAVEL ROADWAY.

(1) COMMERCIAL BUILDING, ASPHALT PAVEMENT PARKING LOTS, CONCRETE SIDEWALK, SKATE PARK, AND PUMP TRACK.

NATURE OF CONSTRUCTION ACTIVITY AND ESTIMATED TIME TABLE

CLEARING (12/23-3/24)
MASS GRADING (12/23-7/24)
UTILITY INSTALLATION (2/24-12/24)
FINAL STABILIZATION (11/24-12/24)

TIME TABLE INCLUDES SANDY PARK PROJECT AND IS FOR THE 1200C PERMITTING REFERENCE.

TOTAL SITE AREA = 444,197 SF = 10.2 ACRES

TOTAL DISTURBED AREA = 161,422 SF = 3.01 ACRES

SITE SOIL CLASSIFICATION

CAZADERO SILTY CLAY LOAM, 7 TO 12 PERCENT SLOPES.

RECEIVING WATER BODIES

ALL WATER IS CONVEYED TO THE SANDY RIVER.

RAIN GAUGE LOCATION

OFFICIAL RAIN GAUGE: NOAA SANDY RIVER NEAR BULL RUN
LAT: 45.448611
LONG: -122.245

<https://water.weather.gov/ahps2/hydrograph.php?wfo=pqr&gage=snd03>

PERMITTEE'S SITE INSPECTOR

XXXX
CESCL NUMBER: XXXX
EXPIRATION DATE: XX/XX/20XX

XXX
CESCL NUMBER: XXX
EXPIRATION DATE: XX/XX/20XX

TEMPORARY EROSION CONTROL SEED MIX

SLENDER HAIRGRASS - 40% WEIGHT
BLUE WILDRYE - 50% WEIGHT
CALIFORNIA BROME - 5% WEIGHT
MEADOW BARLEY - 5% WEIGHT

OR APPROVED EQUAL

DUST CONTROL NOTES:

1. DUST SHALL BE MINIMIZED TO THE EXTENT PRACTICABLE, UTILIZING ALL MEASURES NECESSARY, INCLUDING, BUT NOT LIMITED TO:

- A. SPRINKLER HAUL AND ACCESS ROADS AND OTHER EXPOSED DUST PRODUCING AREAS.
- B. APPLYING AGENCY-APPROVED DUST PALLIATIVES ON ACCESS AND HAUL ROADS.
- C. ESTABLISHING TEMPORARY VEGETATIVE COVER.
- D. PLACING WOOD CHIPS OR OTHER EFFECTIVE MULCHES ON VEHICLE AND PEDESTRIAN USE AREAS.
- E. MAINTAINING THE PROPER MOISTURE CONDITION ON ALL FILL SURFACES.
- F. PREWETTING CUT AND BORROW AREA SURFACES.
- G. USE OF HAUL EQUIPMENT.

2. CONTRACTOR SHALL FURNISH AND INSTALL EQUIPMENT TO HAUL AND PLACE WATER. AN ADEQUATE SUPPLY OF WATER SHALL BE MAINTAINED AT ALL TIMES.

RATIONAL STATEMENT

A COMPREHENSIVE LIST OF AVAILABLE BEST MANAGEMENT PRACTICES (BMP) OPTIONS BASED ON DEQ'S GUIDANCE MANUAL HAS BEEN REVIEWED TO COMPLETE THIS EROSION AND SEDIMENT CONTROL PLAN. SOME OF THE ABOVE LISTED BMP'S WERE NOT CHOSEN BECAUSE THEY WERE DETERMINED TO NOT EFFECTIVELY MANAGE EROSION PREVENTION AND SEDIMENT CONTROL FOR THIS PROJECT BASED ON SPECIFIC SITE CONDITIONS, INCLUDING SOIL CONDITIONS, TOPOGRAPHIC CONSTRAINTS, ACCESSIBILITY TO THE SITE, AND OTHER RELATED CONDITIONS. AS THE PROJECT PROGRESSES AND THERE IS A NEED TO REVISE THE ESC PLAN, AN ACTION PLAN WILL BE SUBMITTED.

INITIAL _____

ATTENTION EXCAVATORS

OREGON LAW REQUIRES YOU TO FOLLOW RULES ADOPTED BY THE OREGON UTILITY NOTIFICATION CENTER. THOSE RULES ARE SET FORTH IN OAR 952-001-0010 THROUGH OAR 952-001-0090. YOU MAY OBTAIN COPIES OF THESE RULES FROM THE CENTER BY CALLING 403-232-1987.

IF YOU HAVE ANY QUESTIONS ABOUT THE RULES, YOU MAY CONTACT THE CENTER. YOU MUST NOTIFY THE CENTER AT LEAST TWO BUSINESS DAYS, BEFORE COMMENCING AND EXCAVATION. CALL 403-246-6699.

INSPECTION FREQUENCY

AT A MINIMUM, THE INSPECTOR MUST DOCUMENT THE INITIAL DATE OF ANY CONSTRUCTION STAGING, CONSTRUCTION ACTIVITIES, OR LAND CLEARING, AND CONDUCT AND DOCUMENT A VISUAL MONITORING INSPECTION OF THE PROJECT SITE PER THE FOLLOWING FREQUENCY:

SITE CONDITION	MINIMUM FREQUENCY
1. ACTIVE PERIOD	ON INITIAL DATE THAT LAND DISTURBANCE ACTIVITIES COMMENCE. WITHIN 24 HOURS OF ANY STORM EVENT, INCLUDING RUNOFF FROM SNOW MELT, THAT RESULTS IN DISCHARGE FROM THE SITE. AT LEAST ONCE EVERY 14 DAYS, REGARDLESS OF WHETHER STORMWATER RUNOFF IS OCCURRING.
2. INACTIVE PERIODS GREATER THAN FOURTEEN (14) CONSECUTIVE CALENDAR DAYS	THE INSPECTOR MAY REDUCE THE FREQUENCY OF INSPECTIONS IN ANY AREA OF THE SITE WHERE THE STABILIZATION STEPS IN SECTION 2.2.20 HAVE BEEN COMPLETED TO TWICE PER MONTH FOR THE FIRST MONTH, NO LESS THAN 14 CALENDAR DAYS APART, THEN ONCE PER MONTH.
3. PERIODS DURING WHICH THE SITE IS INACCESSIBLE DUE TO INCLEMENT WEATHER	IF SAFE, ACCESSIBLE AND PRACTICAL, INSPECTIONS MUST OCCUR DAILY AT A RELEVANT DISCHARGE POINT OR DOWNSTREAM LOCATION OF THE RECEIVING WATERBODY.
4. PERIODS DURING WHICH CONSTRUCTION ACTIVITIES ARE SUSPENDED AND RUNOFF IS UNLIKELY DUE TO FROZEN CONDITIONS	VISUAL MONITORING INSPECTIONS MAY BE TEMPORARILY SUSPENDED. IMMEDIATELY RESUME MONITORING UPON THAWING, OR WHEN WEATHER CONDITIONS MAKE DISCHARGES LIKELY.
5. PERIODS DURING WHICH CONSTRUCTION ACTIVITIES ARE CONDUCTED AND RUNOFF IS UNLIKELY DURING FROZEN CONDITIONS	VISUAL MONITORING INSPECTIONS MAY BE REDUCED TO ONCE A MONTH. IMMEDIATELY RESUME MONITORING UPON THAWING, OR WHEN WEATHER CONDITIONS MAKE DISCHARGES LIKELY.

BMP MATRIX FOR CONSTRUCTION PHASES

REFER TO DEQ GUIDANCE MANUAL FOR A COMPREHENSIVE LIST OF AVAILABLE BMP'S.

BMP'S	YEAR: 2023/2024													
	MONTH:	D	J	F	M	A	M	J	J	A	S	O	N	D
PIPE SLOPE DRAINS														
ENERGY DISSIPATORS														
TEMPORARY DIVERSION DIKES														
CHECK DAMS														
TEMPORARY SEEDING AND PLANTING														
PERMANENT SEEDING AND PLANTING														
MYCORRHIZAE/BIOFERTILIZERS														
MULCHES (SPECIFY TYPE)														
CONSTRUCTION ENTRANCE		X	X	X	X	X	X	X	X	X	X	X	X	X
COMPOST BLANKETS														
COMPOST SOCKS														
COMPOST BERM														
SOIL TACKIFIERS														
SEEDING VEGETATIVE BUFFER STRIPS														
PLASTIC SHEETING														
SEDIMENT FENCING		X	X	X	X	X	X	X	X	X	X	X	X	X
EROSION CONTROL BLANKETS & MATS (SPECIFY TYPE)														
EARTH DIKES (STABILIZED)														
DRAINAGE SWALES														
ROCK OUTLET PROTECTION														
SEDIMENT TRAP														
STRAW WATTLES (LOOSE COMPACTION RICE STRAW)														
STORM DRAIN INLET PROTECTION		X	X	X	X	X	X	X	X	X	X	X	X	X
TEMPORARY OR PERMANENT SEDIMENTATION BASINS														
UNPAVED ROADS GRAVELED OR OTHER BMP ON THE ROAD								X	X	X	X	X	X	X
DEWATERING (TREATMENT LOCATION, SCHEMATIC, & SAMPLING PLAN REQUIRED)														
PAVING OPERATIONS CONTROLS														
CONCRETE TRUCK WASHOUT		X	X	X	X	X	X	X	X	X	X	X	X	X

AUTHORIZED NON-STORMWATER DISCHARGES

1. THE FOLLOWING NON-STORMWATER DISCHARGES FROM CONSTRUCTION ARE AUTHORIZED IF THE TERMS AND CONDITIONS OF THIS PERMIT ARE MET:

- A. WATER AND ASSOCIATED DISCHARGED FROM EMERGENCY FIREFIGHTING ACTIVITIES.
- B. PROPERLY MANAGED LANDSCAPE IRRIGATION.
- C. WATER USED TO WAS EQUIPMENT AND VEHICLES (EXCLUDING THE ENGINE, UNDERCARRIAGE, AND WHEELS/TIRES) PROVIDED THERE IS NO DISCHARGE OF SOAPS, SOLVENTS, OR DETERGENTS USED.
- D. WATER USED TO CONTROL DUST.
- E. POTABLE WATER INCLUDING UNCONTAMINATED WATER LINE FLUSHINGS.
- F. EXTERNAL BUILDING WASHDOWN, PROVIDED SOAPS, SOLVENTS, AND DETERGENTS ARE NOT USED, AND EXTERNAL SURFACES DO NOT CONTAIN HAZARDOUS SUBSTANCES. PAVEMENT WAS WATERS, PROVIDED SPILLS OR LEAKS OF TOXIC OR HAZARDOUS SUBSTANCES HAVE NOT OCCURRED (UNLESS ALL SPILL MATERIAL HAS BEEN REMOVED) AND WHERE SOAPS, SOLVENTS, AND DETERGENTS ARE NOT USED. DIRECTING PAVEMENT WAS WATERS INTO ANY SURFACE WATER, STORM DRAIN INLET, OR STORMWATER CONVEYANCE IS PROHIBITED, UNLESS THE CONVEYANCE IS CONNECT TO A SEDIMENT BASIN, SEDIMENT TRAP, OR SIMILAR EFFECTIVE CONTROL FOR THE POLLUTANTS PRESENT. PER 2.2.19.B, HOUSING OF ACCUMULATED SEDIMENTS ON PAVEMENT INTO ANY STORMWATER CONVEYANCE IS PROHIBITED.
- G. UNCONTAMINATED AIR CONDITIONING OR COMPRESSOR CONDENSATE.
- H. UNCONTAMINATED, NON-TURBID DISCHARGES OF GROUNDWATER OR SPRINGWATER.
- I. FOUNDATION OR FOOTING DRAINS WHERE FLOWS ARE NOT CONTAMINATED WITH PROCESS MATERIALS SUCH AS SOLVENTS OR CONTAMINATED GROUNDWATER.
- J. CONSTRUCTION DEWATERING ACTIVITIES (INCLUDING GROUNDWATER DEWATERING AND WELL DRILLING DISCHARGE ASSOCIATED WITH THE REGISTERED CONSTRUCTION ACTIVITY), PROVIDED THAT:
 - a) THE WATER IS LAND APPLIED IN A WAY THAT RESULTS IN COMPLETE INFILTRATION WITH NO POTENTIAL TO DISCHARGE TO A SURFACE WATER OF THE STATE, OR THE USE OF A SANITARY OR COMBINED SEWER DISCHARGE IS AUTHORIZED WITH LOCAL SEWER DISTRICT APPROVAL.
 - b) BEST MANAGEMENT PRACTICED AND A TREATMENT SYSTEM APPROVED BY DEQ OR AGENT (SEE SECTION 1.2.9) ARE USED TO ENSURE COMPLIANCE WITH DISCHARGE AND WATER QUALITY REQUIREMENTS IN SECTION 2.4.

SHEET INDEX

C6.00	EROSION AND SEDIMENT CONTROL COVER SHEET
C6.01	EROSION AND SEDIMENT CONTROL NOTES
C6.02	OVERALL SITE PLAN
C6.03	CLEARING AND DEMOLITION ESC PLAN-SCHOOL
C6.04	CLEARING AND DEMOLITION ESC PLAN-PARK
C6.05	MASS GRADING AND UTILITY ESC PLAN-SCHOOL
C6.06	MASS GRADING AND UTILITY ESC PLAN-PARK
C6.07	VERTICAL CONSTRUCTION ESC PLAN-SCHOOL
C6.08	VERTICAL CONSTRUCTION ESC PLAN-PARK
C6.09	FINAL STABILIZATION PLAN-SCHOOL
C6.10	FINAL STABILIZATION PLAN-PARK
C6.11	EROSION AND SEDIMENT CONTROL DETAILS



RENEWAL DATE 6/30/2024

THE PERMITTEE IS REQUIRED TO MEET ALL THE CONDITIONS OF THE 1200C PERMIT. THIS ESCP AND GENERAL CONDITIONS HAVE BEEN DEVELOPED TO FACILITATE COMPLIANCE WITH THE 1200C PERMIT REQUIREMENTS. IN CASES OF DISCREPANCIES OR OMISSIONS, THE 1200C PERMIT REQUIREMENTS SUPERCEDE REQUIREMENTS OF THIS PLAN.

EROSION CONTROL NOTES:

1. INCLUDE A LIST OF ALL PERSONNEL (BY NAME AND POSITION) THAT ARE RESPONSIBLE FOR THE DESIGN, INSTALLATION AND MAINTENANCE OF STORMWATER CONTROL MEASURES (E.G. ESCP DEVELOPER, BMP INSTALLER (SEE SECTION 4.10), AS WELL AS THEIR INDIVIDUAL RESPONSIBILITIES. (SECTION 4.4.C.II)
2. VISUAL MONITORING INSPECTION REPORTS MUST BE MADE IN ACCORDANCE WITH DEQ 1200-C PERMIT REQUIREMENTS. (SECTION 6.5)
3. INSPECTION LOGS MUST BE KEPT IN ACCORDANCE WITH DEQ'S 1200-C PERMIT REQUIREMENTS. (SECTION 6.5.Q)
4. RETAIN A COPY OF THE ESCP AND ALL REVISIONS ON SITE AND MAKE IT AVAILABLE ON REQUEST TO DEQ, AGENT, OR THE LOCAL MUNICIPALITY. (SECTION 4.7)
5. THE PERMIT REGISTRANT MUST IMPLEMENT THE ESCP. FAILURE TO IMPLEMENT ANY OF THE CONTROL MEASURES OR PRACTICES DESCRIBED IN THE ESCP IS A VIOLATION OF THE PERMIT. (SECTIONS 4 AND 4.11)
6. THE ESCP MUST BE ACCURATE AND REFLECT SITE CONDITIONS. (SECTION 4.8)
7. SUBMISSION OF ALL ESCP REVISIONS IS NOT REQUIRED. SUBMITTAL OF THE ESCP REVISIONS IS ONLY UNDER SPECIFIC CONDITIONS. SUBMIT ALL NECESSARY REVISION TO DEQ OR AGENT WITHIN 10 DAYS. (SECTION 4.9)
8. SEQUENCE CLEARING AND GRADING TO THE MAXIMUM EXTENT PRACTICAL TO PREVENT EXPOSED INACTIVE AREAS FROM BECOMING A SOURCE OF EROSION. (SECTION 2.2.2)
9. CREATE SMOOTH SURFACES BETWEEN SOIL SURFACE AND EROSION AND SEDIMENT CONTROLS TO PREVENT STORMWATER FROM BYPASSING CONTROLS AND PONDING. (SECTION 2.2.3)
10. IDENTIFY, MARK, AND PROTECT (BY CONSTRUCTION FENCING OR OTHER MEANS) CRITICAL RIPARIAN AREAS AND VEGETATION INCLUDING IMPORTANT TREES AND ASSOCIATED ROOTING ZONES, AND VEGETATION AREAS TO BE PRESERVED. IDENTIFY VEGETATIVE BUFFER ZONES BETWEEN THE SITE AND SENSITIVE AREAS (E.G., WETLANDS) AND OTHER AREAS TO BE PRESERVED, ESPECIALLY IN PERIMETER AREAS. (SECTION 2.2.1)
11. PRESERVE EXISTING VEGETATION WHEN PRACTICAL AND RE-VEGETATE OPEN AREAS. RE-VEGETATE OPEN AREAS WHEN PRACTICABLE BEFORE AND AFTER GRADING OR CONSTRUCTION. IDENTIFY THE TYPE OF VEGETATIVE SEED MIX USED. (SECTION 2.2.5)
12. MAINTAIN AND DELINEATE ANY EXISTING NATURAL BUFFER WITHIN THE 50- FEET OF WATERS OF THE STATE. (SECTION 2.2.4)
13. INSTALL PERIMETER SEDIMENT CONTROL, INCLUDING STORM DRAIN INLET PROTECTION AS WELL AS ALL SEDIMENT BASINS, TRAPS, AND BARRIERS PRIOR TO LAND DISTURBANCE. (SECTIONS 2.1.3)
14. CONTROL BOTH PEAK FLOW RATES AND TOTAL STORMWATER VOLUME, TO MINIMIZE EROSION AT OUTLETS AND DOWNSTREAM CHANNELS AND STREAMBANKS. (SECTIONS 2.1.1. AND 2.2.16)
15. CONTROL SEDIMENT AS NEEDED ALONG THE SITE PERIMETER AND AT ALL OPERATIONAL INTERNAL STORM DRAIN INLETS AT ALL TIMES DURING CONSTRUCTION, BOTH INTERNALLY AND AT THE SITE BOUNDARY. (SECTIONS 2.2.6 AND 2.2.13)
16. ESTABLISH CONCRETE TRUCK AND OTHER CONCRETE EQUIPMENT WASHOUT AREAS BEFORE BEGINNING CONCRETE WORK. (SECTION 2.2.14)
17. APPLY TEMPORARY AND/OR PERMANENT SOIL STABILIZATION MEASURES IMMEDIATELY ON ALL DISTURBED AREAS AS GRADING PROGRESSES. TEMPORARY OR PERMANENT STABILIZATION MEASURES ARE NOT REQUIRED FOR AREAS THAT ARE INTENDED TO BE LEFT UNVEGETATED, SUCH AS DIRT ACCESS ROADS OR UTILITY POLE PADS.(SECTIONS 2.2.20 AND 2.2.21)
18. ESTABLISH MATERIAL AND WASTE STORAGE AREAS, AND OTHER NON-STORMWATER CONTROLS. (SECTION 2.3.7)
19. KEEP WASTE CONTAINER LIDS CLOSED WHEN NOT IN USE AND CLOSE LIDS AT THE END OF THE BUSINESS DAY FOR THOSE CONTAINERS THAT ARE ACTIVELY USED THROUGHOUT THE DAY; FOR WASTE CONTAINERS THAT DO NOT HAVE LIDS, PROVIDE EITHER (1) COVER (E.G. A TARP, PLASTIC SHEETING, TEMPORARY ROOF) TO PREVENT EXPOSURE OF WASTES TO PRECIPITATION, OR (2) A SIMILARLY EFFECTIVE MEANS DESIGNED TO PREVENT THE DISCHARGE OF POLLUTANTS (E.G., SECONDARY CONTAINMENT). (SECTION 2.3.7)
20. PREVENT TRACKING OF SEDIMENT ONTO PUBLIC OR PRIVATE ROADS USING BMPS SUCH AS: CONSTRUCTION ENTRANCE, GRAVELED (OR PAVED) EXITS AND PARKING AREAS, GRAVEL ALL UNPAVED ROADS LOCATED ONSITE, OR USE AN EXIT TIRE WASH. THESE BMPS MUST BE IN PLACE PRIOR TO LAND- DISTURBING ACTIVITIES. (SECTION 2.2.7)
21. WHEN TRUCKING SATURATED SOILS FROM THE SITE, EITHER USE WATER-TIGHT TRUCKS OR DRAIN LOADS ON SITE. (SECTION 2.2.7.F)
22. CONTROL PROHIBITED DISCHARGES FROM LEAVING THE CONSTRUCTION SITE, I.E., CONCRETE WASH-OUT, WASTEWATER FROM CLEANOUT OF STUCCO, PAINT AND CURING COMPOUNDS. (SECTIONS 1.5 AND 2.3.9)
23. ENSURE THAT STEEP SLOPE AREAS WHERE CONSTRUCTION ACTIVITIES ARE NOT OCCURRING ARE NOT DISTURBED. (SECTION 2.2.10)
24. PREVENT SOIL COMPACTION IN AREAS WHERE POST-CONSTRUCTION INFILTRATION FACILITIES ARE TO BE INSTALLED. (SECTION 2.2.12)
25. USE BMPS TO PREVENT OR MINIMIZE STORMWATER EXPOSURE TO POLLUTANTS FROM SPILLS; VEHICLE AND EQUIPMENT FUELING, MAINTENANCE, AND STORAGE; OTHER CLEANING AND MAINTENANCE ACTIVITIES; AND WASTE HANDLING ACTIVITIES. THESE POLLUTANTS INCLUDE FUEL, HYDRAULIC FLUID, AND OTHER OILS FROM VEHICLES AND MACHINERY, AS WELL AS DEBRIS, FERTILIZER, PESTICIDES AND HERBICIDES, PAINTS, SOLVENTS, CURING COMPOUNDS AND ADHESIVES FROM CONSTRUCTION OPERATIONS. (SECTIONS 2.2.15 AND 2.3)
26. PROVIDE PLANS FOR SEDIMENTATION BASINS THAT HAVE BEEN DESIGNED PER SECTION 2.2.17 AND STAMPED BY AN OREGON PROFESSIONAL ENGINEER. (SEE SECTION 2.2.17.A)
27. IF ENGINEERED SOILS ARE USED ON SITE, A SEDIMENTATION BASIN/IMPOUNDMENT MUST BE INSTALLED. (SEE SECTIONS 2.2.17 AND 2.2.18)
28. PROVIDE A DETERMINING PLAN FOR ACCUMULATED WATER FROM PRECIPITATION AND UNCONTAMINATED GROUNDWATER SEEPAGE DUE TO SHALLOW EXCAVATION ACTIVITIES. (SEE SECTION 2.4)
29. IMPLEMENT THE FOLLOWING BMPS WHEN APPLICABLE: WRITTEN SPILL PREVENTION AND RESPONSE PROCEDURES, EMPLOYEE TRAINING ON SPILL PREVENTION AND PROPER DISPOSAL PROCEDURES, SPILL KITS IN ALL VEHICLES, REGULAR MAINTENANCE SCHEDULE FOR VEHICLES AND MACHINERY, MATERIAL DELIVERY AND STORAGE CONTROLS, TRAINING AND SIGNAGE, AND COVERED STORAGE AREAS FOR WASTE AND SUPPLIES. (SECTION 2.3)
30. USE WATER, SOIL-BINDING AGENT OR OTHER DUST CONTROL TECHNIQUE AS NEEDED TO AVOID WIND-BLOWN SOIL. (SECTION 2.2.9)
31. THE APPLICATION RATE OF FERTILIZERS USED TO REESTABLISH VEGETATION MUST FOLLOW MANUFACTURER'S RECOMMENDATIONS TO MINIMIZE NUTRIENT RELEASES TO SURFACE WATERS. EXERCISE CAUTION WHEN USING TIME-RELEASE FERTILIZERS WITHIN ANY WATERWAY RIPARIAN ZONE. (SECTION 2.3.5)
32. IF AN ACTIVE TREATMENT SYSTEM (FOR EXAMPLE, ELECTRO-COAGULATION, FLOCCULATION, FILTRATION, ETC.) FOR SEDIMENT OR OTHER POLLUTANT REMOVAL IS EMPLOYED, SUBMIT AN OPERATION AND MAINTENANCE PLAN (INCLUDING SYSTEM SCHEMATIC, LOCATION OF SYSTEM, LOCATION OF INLET, LOCATION OF DISCHARGE, DISCHARGE DISPERSION DEVICE DESIGN, AND A SAMPLING PLAN AND FREQUENCY) BEFORE OPERATING THE TREATMENT SYSTEM. OBTAIN ENVIRONMENTAL MANAGEMENT PLAN APPROVAL FROM DEQ BEFORE OPERATING THE TREATMENT SYSTEM. OPERATE AND MAINTAIN THE TREATMENT SYSTEM ACCORDING TO MANUFACTURER'S SPECIFICATIONS. (SECTION 1.2.9)
33. TEMPORARILY STABILIZE SOILS AT THE END OF THE SHIFT BEFORE HOLIDAYS AND WEEKENDS, IF NEEDED. THE REGISTRANT IS RESPONSIBLE FOR ENSURING THAT SOILS ARE STABLE DURING RAIN EVENTS AT ALL TIMES OF THE YEAR. (SECTION 2.2)
34. AS NEEDED BASED ON WEATHER CONDITIONS, AT THE END OF EACH WORKDAY SOIL STOCKPILES MUST BE STABILIZED OR COVERED, OR OTHER BMPS MUST BE IMPLEMENTED TO PREVENT DISCHARGES TO SURFACE WATERS OR CONVEYANCE SYSTEMS LEADING TO SURFACE WATERS. (SECTION 2.2.8)
35. SEDIMENT FENCE: REMOVE TRAPPED SEDIMENT BEFORE IT REACHES ONE THIRD OF THE ABOVE GROUND FENCE HEIGHT AND BEFORE FENCE REMOVAL. (SECTION 2.1.5.B)
36. OTHER SEDIMENT BARRIERS (SUCH AS BIOBAGS): REMOVE SEDIMENT BEFORE IT REACHES TWO INCHES DEPTH ABOVE GROUND HEIGHT AND BEFORE BMP REMOVAL. (SECTION 2.1.5.C)
37. CATCH BASINS: CLEAN BEFORE RETENTION CAPACITY HAS BEEN REDUCED BY FIFTY PERCENT. SEDIMENT BASINS AND SEDIMENT TRAPS: REMOVE TRAPPED SEDIMENTS BEFORE DESIGN CAPACITY HAS BEEN REDUCED BY FIFTY PERCENT AND AT COMPLETION OF PROJECT. (SECTION 2.1.5.D)
38. WITHIN 24 HOURS, SIGNIFICANT SEDIMENT THAT HAS LEFT THE CONSTRUCTION SITE, MUST BE REMEDIATED. INVESTIGATE THE CAUSE OF THE SEDIMENT RELEASE AND IMPLEMENT STEPS TO PREVENT A RECURRENCE OF THE DISCHARGE WITHIN THE SAME 24 HOURS. ANY IN-STREAM CLEAN-UP OF SEDIMENT SHALL BE PERFORMED ACCORDING TO THE OREGON DEPARTMENT OF STATE LANDS REQUIRED TIMEFRAME. (SECTION 2.2.19.A)
39. THE INTENTIONAL WASHING OF SEDIMENT INTO STORM SEWERS OR DRAINAGE WAYS MUST NOT OCCUR. VACUUMING OR DRY SWEEPING AND MATERIAL PICKUP MUST BE USED TO CLEANUP RELEASED SEDIMENTS. (SECTION 2.2.19)
40. DOCUMENT ANY PORTION(S) OF THE SITE WHERE LAND DISTURBING ACTIVITIES HAVE PERMANENTLY CEASED OR WILL BE TEMPORARILY INACTIVE FOR 14 OR MORE CALENDAR DAYS. (SECTION 6.5.F.)
41. PROVIDE TEMPORARY STABILIZATION FOR THAT PORTION OF THE SITE WHERE CONSTRUCTION ACTIVITIES CEASE FOR 14 DAYS OR MORE WITH A COVERING OF BLOWN STRAW AND A TACKIFIER, LOOSE STRAW, OR AN ADEQUATE COVERING OF COMPOST MULCH UNTIL WORK RESUMES ON THAT PORTION OF THE SITE. (SECTION 2.2.20)
42. DO NOT REMOVE TEMPORARY SEDIMENT CONTROL PRACTICES UNTIL PERMANENT VEGETATION OR OTHER COVER OF EXPOSED AREAS IS ESTABLISHED. ONCE CONSTRUCTION IS COMPLETE AND THE SITE IS STABILIZED, ALL TEMPORARY EROSION CONTROLS AND RETAINED SOILS MUST BE REMOVED AND DISPOSED OF PROPERLY, UNLESS NEEDED FOR LONG TERM USE FOLLOWING TERMINATION OF PERMIT COVERAGE. (SECTION 2.2.21)

LOCAL AGENCY-SPECIFIC EROSION CONTROL NOTES:

1. OWNER OR DESIGNATED PERSON SHALL BE RESPONSIBLE FOR PROPER INSTALLATION AND MAINTENANCE OF ALL EROSION AND SEDIMENT CONTROL MEASURES, IN ACCORDANCE WITH LOCAL, STATE, AND FEDERAL REGULATIONS.
2. PRIOR TO ANY LAND DISTURBING ACTIVITIES, THE BOUNDARIES OF THE CLEARING LIMITS, VEGETATED BUFFERS, AND ANY SENSITIVE AREAS SHOWN ON THIS PLAN SHALL BE CLEARLY DELINEATED IN THE FIELD. DURING THE CONSTRUCTION PERIOD, NO DISTURBANCE IS PERMITTED BEYOND THE CLEARING LIMITS. THE OWNER/PERMITTEE MUST MAINTAIN THE DELINEATION FOR THE DURATION OF THE PROJECT. NOTE: VEGETATED CORRIDORS TO BE DELINEATED WITH ORANGE CONSTRUCTION FENCE OR APPROVED EQUAL.
3. PRIOR TO ANY LAND DISTURBING ACTIVITIES, THE BMP'S THAT MUST BE INSTALLED ARE A GRAVEL CONSTRUCTION ENTRANCE, PERIMETER SEDIMENT CONTROL, AND INLET PROTECTION. THESE BMP'S MUST BE MAINTAINED FOR THE DURATION OF THE PROJECT.
4. IF VEGETATIVE SEED MIXES ARE SPECIFIED, SEEDING MUST TAKE PLACE NO LATER THAN SEPTEMBER 1; THE TYPE AND PERCENTAGES OF SEED IN THE MIX MUST BE IDENTIFIED ON THE PLANS.
5. THE ESC PLAN MUST BE KEPT ON SITE. ALL MEASURES SHOWN ON THE PLAN MUST BE INSTALLED PROPERLY TO ENSURE THAT SEDIMENT OR SEDIMENT LADEN WATER DOES NOT ENTER A SURFACE WATER SYSTEM, ROADWAY, OR OTHER PROPERTIES.
6. THE ESC MEASURES SHOWN ON THIS PLAN ARE MINIMUM REQUIREMENTS FOR ANTICIPATED SITE CONDITIONS. DURING THE CONSTRUCTION PERIOD, THESE MEASURES SHALL BE UPGRADED AS NEEDED TO COMPLY WITH ALL APPLICABLE LOCAL, STATE, AND FEDERAL EROSION CONTROL REGULATIONS. CHANGES TO THE APPROVED ESC PLAN MUST BE SUBMITTED IN THE FORM OF AN ACTION PLAN TO DEQ PER THE 1200 C PERMIT.
7. IN AREAS SUBJECT TO WIND EROSION, APPROPRIATE BMP'S MUST BE USED WHICH MAY INCLUDE THE APPLICATION OF FINE WATER SPRAYING, PLASTIC SHEETING, MULCHING, OR OTHER APPROVED MEASURES.

STRAW WATTLE NOTES

1. STRAW WATTLES ARE BIODEGRADABLE AND COMPOSED OF WEED-FREE VEGETATIVE MATERIALS.
2. STAKES SHALL BE INSTALLED AS SHOWN IN DETAIL2, SHEET C405.
3. STRAW WATTLES SHALL BE INSPECTED DAILY. SEDIMENT DEPTH SHALL NOT ACCUMULATE TO MORE THAN ONE-THIRD THE HEIGHT OF THE STRAW WATTLE.
4. SEDIMENT SHALL BE REMOVED OR RE-GRADED ONTO THE SLOPE, OR NEW STRAW WATTLES SHALL BE INSTALLED UPHILL OF SEDIMENT-LADEN BARRIERS.
5. REMOVE SEDIMENT BUILDUP, AND REPLACE OR ADD ADDITIONAL STRAW WATTLE WHEN ONE-THIRD OF CAPACITY IS FULL.
6. CHECK PLACEMENTS, PERFORMANCE, AND REMAINING CAPACITY OFTEN, SINCE HIGH FLOWS CAN LIMIT PERFORMANCE AND DAMAGE ROLLS.
7. ENSURE THAT NO GAPS EXIST UNDER OR BETWEEN ROLLS THAT COULD BYPASS FLOWS. OVERLAP STRAW WATTLES WHENEVER POSSIBLE.
8. PLACE SANDBAGS OVER WATTLES TO IMPROVE GROUND CONTACT ON IMPERVIOUS SURFACES, OR USE MANUFACTURED WEIGHTED WATTLES.

SOIL CONTAMINATION NOTES

1. CHARACTERISTICS OF SOIL CONTAMINATION INCLUDE VISUAL STAINING (TYPICALLY GRAY, BLuish, OR GREENISH IN COLOR), UNUSUAL ODORS, AND VISIBLE SHEEN ON THE SOIL OR WHEN PLACED IN WATER.
2. IF SOIL CONTAMINATION IS SUSPECTED HALT WORK, OR REMOVE AND STOCKPILE THE SUSPECT SOILS. NOTIFY DESIGNATED ENVIRONMENTAL CONSULTANT, EITHER DISPOSE OF THE SUSPECT SOILS AT A DESIGNATED LANDFILL (ASSUMING SOILS HAVE BEEN PRE-APPROVED FOR ACCEPTANCE) OR TEST THE IN-PLACE OR STOCKPILED SOILS TO CHARACTERIZE AND DETERMINE AN APPROPRIATE DISPOSAL LOCATION. IF FREE PRODUCT (NON-AQUEOUS PHASE LIQUID) IS ENCOUNTERED, NOTIFY DEQ WITHIN 48 HOURS OF DISCOVERY.
3. IF SOIL CONTAMINATION IS CONFIRMED DETERMINE A DISPOSAL LOCATION BASED ON TESTING RESULTS, CONDUCT REMOVAL OF IMPACTED SOILS TO EXTENT NECESSARY TO PREPARE THE SITE FOR CONSTRUCTION, AND/OR MEET APPROPRIATE OREGON DEQ RISK-BASED CONCENTRATIONS (RBCS), FOLLOWING SOIL REMOVAL CONFIRMATION SAMPLES SHOULD BE COLLECTED BY CONTRACTOR TO VERIFY REMAINING SOILS MEET APPROPRIATE DEQ RBCS, PHOTOGRAPH AND MEASURE THE AFFECTED AREA AS WELL AS COLLECT LANDFILL RECEIPTS TO DOCUMENT THE SOIL REMOVAL ACTIVITIES.
4. TO PREVENT OFF-SITE TRACKING OF SOIL VIA VEHICLES AND EQUIPMENT, USE LIMITED ENTRANCES/EXITS, SPECIFIED ON-SITE TRUCK ROUTES, AND GRAVEL PADS AND ROADWAYS WHENEVER POSSIBLE. PHYSICALLY REMOVE SOIL FROM VEHICLES AND USE A WHEEL WASH AREA IF NECESSARY. BEFORE LEAVING THE PROPERTY, ALL VEHICLES WILL BE INSPECTED BY THEIR OCCUPANTS FOR ADHERED SOIL. SOIL WITH FREE WATER WILL NOT BE LOADED INTO TRUCKS. ALL TRUCKS WILL BE APPROPRIATELY COVERED AND SECURED BEFORE LEAVING THE SITE.
5. DUST CONTROL MEASURES SHOULD BE IMPLEMENTED AS NECESSARY.
6. STOCKPILES OF IMPACTED SOIL MAY BE TEMPORARILY (LESS THAN 30 DAYS) STORED ON-SITE PRIOR TO OFF-SITE TRANSPORT. STOCKPILES SHOULD NOT BE PLACED DIRECTLY ON CLEAN AREAS. STOCKPILES SHALL BE COVERED DAILY USING A MINIMUM 6-MIL MEMBRANE AND COVERS SHALL BE SECURELY ANCHORED OR STORED IN LINED 10-YD DROP BOX WITH LID. STOCKPILES SHALL HAVE A BARRIER ON ALL FOUR SIDES, BE COVERED TO PROTECT MATERIALS FROM STORMWATER CONTACT, AND HAVE AN IMPERVIOUS LAYER UNDERNEATH.
7. BES REQUIRES ADDITIONAL EROSION CONTROL MEASURES WHEN CONTAMINATED MEDIA IS BEING HANDLED AND STORED ONSITE. IN THE EVENT THAT CONTAMINATED SOILS ARE ENCOUNTERED DURING SITE DEVELOPMENT ACTIVITIES, THE STOCKPILES OF CONTAMINATED MEDIA ARE SUBJECT TO THE FOLLOWING MANAGEMENT STANDARDS:
 - 7.1. STOCKPILES OF SOIL MUST BE COVERED TO PROTECT MATERIALS FROM STORMWATER CONTACT.
 - 7.2. STOCKPILE PERIMETERS MUST HAVE A CONTAMINANT BARRIER ON ALL FOUR SIDES OF EVERY STOCKPILE.
 - 7.3. STOCKPILES OF SOIL MUST HAVE AN IMPERVIOUS LAYER UNDERNEATH THE STOCKPILE.
 - 7.4. SITE CONTROLS MUST BE EMPLOYED THAT PROTECT DRAG-OUT INTO A CITY STREET FROM THE DEVELOPMENT SITE AND DAY-TO-DAY OPERATIONS.
 - 7.5. IF IMPACTED SOIL IS STOCKPILED, INSPECT ALL INLET PROTECTION INSERTS DAILY AND ADDITIONAL PROTECTIVE BMPS APPLIED IF SIGNIFICANT SEDIMENT IS PRESENT AT THE INLET.
8. THE CONTAMINATED MEDIA MANAGEMENT PLAN (CMMP) APPROVED BY DEQ MUST BE FOLLOWED FOR ANY FOUNDATION/SUBSURFACE REMOVAL. SPECIFIC NOTES FROM THE DEQ-APPROVED PLAN MUST BE ON ALL PERTINENT EXCAVATION AND EROSION CONTROL SHEETS THAT EXPLAIN MATERIAL HANDLING/DISPOSAL PROCEDURES AND TESTING REQUIREMENTS.
9. ALL STOCKPILES AND BMPS ARE TO BE PROTECTED DURING WET WEATHER AND PERIODS OF INACTIVITY.

SPILL PREVENTION CONTROL AND COUNTERMEASURE

1. PROCEDURES FOR EXPEDITIOUSLY STOPPING, CONTAINING, AND CLEANING UP SPILLS, LEAKS, AND OTHER RELEASES.
2. GENERAL CONDITIONS:
 - A. PROVIDE AN EFFECTIVE MEANS OF ELIMINATING THE DISCHARGE OF ANY WASTE FROM ANY ACTIVITIES PERFORMED ON SITE BY IMPLEMENTING THE FOLLOWING:
 - a) LOCATE ACTIVITIES AWAY FROM WATER OF THE STATE AND STORMWATER INLETS OR CONVEYANCES SO THAT STORMWATER COMING INTO CONTACT WITH THESE ACTIVITIES CANNOT REACH THE WATERS OF THE STATE.
 - b) ENSURE ADEQUATE SUPPLIES ARE AVAILABLE AT ALL TIMES TO HANDLE SPILLS, LEAKS, AND DISPOSAL OF LIQUIDS, AND PROVIDE SECONDARY CONTAINMENT (E.G. SPILL BERMS, DECKS, SPILL CONTAINMENT PALLETS).
 - c) HAVE A SPILL KIT AVAILABLE ON SITE AND ENSURE PERSONNEL ARE AVAILABLE ON SITE AND ENSURE PERSONNEL ARE AVAILABLE TO EXPEDITIOUSLY IN THE EVENT OF A LEAK OR SPILL.
 - d) CLEAN UP SPILLS OR CONTAMINATED SURFACES IMMEDIATELY USING DRY CLEAN UP MEASURES (DO NOT CLEAN CONTAMINATED SURFACES BY HOSING THE AREA DOWN), AND ELIMINATE THE SOURCE F THE SPILL TO PREVENT A DISCHARGE OR A CONTINUATION OF AN ONGOING DISCHARGE.
 - e) STORE MATERIALS IN A COVERED AREA (E.G. PLASTIC SHEETING, TEMPORARY ROOFS), OR IN SECONDARY CONTAINMENT TO PREVENT THE EXPOSURE OF THESE CONTAINERS TO PRECIPITATION OR STORMWATER RUNOFF, OR A SIMILARLY EFFECTIVE MEANS DESIGNED TO PREVENT THE DISCHARGE OF POLLUTANTS FROM THE AREAS.
 3. EQUIPMENT AND VEHICLE FUELING AND MAINTENANCE:
 - A. USE DRIP PANS AND ABSORBENTS UNDER OR AROUND VEHICLES.
 - B. DISPOSE OF OR RECYCLE OIL AND OILY WASTES IN ACCORDANCE WITH OTHER FEDERAL, STATE, TRIBAL, OR LOCAL REQUIREMENTS.
 4. EQUIPMENT AND VEHICLE WASHING:
 - A. ENSURE THERE IS NO DISCHARGE OF SOAPS, SOLVENTS, OR DETERGENTS IN EQUIPMENT AND VEHICLE WASH WATER.
 - B. PREVENT THE DISCHARGE OF TURBID VEHICLE WASH WATER TO WATERS OF THE STATE OR CONVEYANCES THAT LEAD TO WATERS OF THE STATE.
 5. BUILDING MATERIALS AND BUILDING PRODUCTS:
 - A. MINIMIZE MATERIAL EXPOSURE IN CASES WHERE THE EXPOSURE TO PRECIPITATION OR TO STORMWATER WILL RESULT IN A DISCHARGE OF POLLUTANTS (E.G. ELEVATE MATERIALS FROM SOIL TO PREVENT LEACHING OF POLLUTANTS).
 6. PESTICIDES, HERBICIDES, INSECTICIDES, AND FERTILIZERS:
 - A. COMPLY WITH ALL APPLICATION AND DISPOSAL REQUIREMENTS INCLUDED ON THE REGISTERED PESTICIDE, HERBICIDE, INSECTICIDE, AND FERTILIZER LABEL. WHEN APPLYING FERTILIZERS, REGISTRANTS MUST:
 - a) APPLY AT A RATE AND IN AMOUNTS CONSISTENT WITH MANUFACTURER'S SPECIFICATIONS.
 - b) APPLY AT THE APPROPRIATE TIME OF YEAR FOR THE LOCATION, AND PREFERABLY TIMED TO COINCIDE AS CLOSELY AS POSSIBLE TO THE PERIOD OF MAXIMUM VEGETATION UPTAKE AND GROWTH.
 - c) AVOID APPLYING BEFORE HEAVY RAINS THAT COULD CAUSE EXCESS NUTRIENTS TO BE DISCHARGED.
 - d) NEVER APPLY TO FROZEN GROUND.
 - e) NEVER APPLY TO STORMWATER CONVEYANCE CHANNELS.
 - f) FOLLOW ALL OTHER FEDERAL, STATE, AND LOCAL REQUIREMENTS REGARDING FERTILIZER APPLICATION.
 7. HAZARDOUS OR TOXIC WASTES:
 - A. SEPARATE HAZARDOUS OR TOXIC WASTE FROM CONSTRUCTION AND DOMESTIC WASTE.
 - B. STORE WASTE IN SEALED CONTAINERS, WHICH ARE CONSTRUCTED OF SUITABLE MATERIALS TO PREVENT LEAKAGE AND CORROSION, AND WHICH ARE CLEARLY LABELED WITH THEIR CONTENTS IN ACCORDANCE WITH ALL APPLICABLE FEDERAL, STATE, TRIBAL, OR LOCAL REQUIREMENTS.
 - C. STORE ALL OUTSIDE CONTAINERS WITHIN APPROPRIATELY-SIZED SECONDARY CONTAINMENT (E.G. SPILL BERMS, DECKS, SPILL CONTAINMENT PALLETS) TO PREVENT SPILLS FROM BEING DISCHARGED, OR PROVIDE A SIMILARLY EFFECTIVE MEANS DESIGNED TO PREVENT THE DISCHARGE OF POLLUTANTS FROM THESE AREAS (E.G. STORING CHEMICALS IN A COVERED AREA, HAVING A SPILL KIT AVAILABLE ON SITE).
 - D. DISPOSE OF HAZARDOUS OR TOXIC WASTE IN ACCORDANCE WITH THE MANUFACTURER'S RECOMMENDED METHOD OF DISPOSAL AND IN COMPLIANCE WITH FEDERAL, STATE, TRIBAL, AND LOCAL REQUIREMENTS.
 8. CONSTRUCTION AND DOMESTIC WASTES:
 - A. PROVIDE WASTE CONTAINERS (E.G. DUMPSTER, TRASH RECEPTACLE) THAT PROVIDE GROUND SEPARATION AND ARE OF SUFFICIENT SIZE AND NUMBER TO CONTAIN CONSTRUCTION AND DOMESTIC WASTES.
 - B. KEEP WASTE CONTAINER LIDS CLOSED WHEN NOT IN USE AND CLOSE LIDS AT THE END OF THE BUSINESS DAY FOR THOSE CONTAINERS THAT ARE ACTIVELY USED THROUGHOUT THE DAY. FOR WASTE CONTAINERS THAT DO NOT HAVE LIDS, PROVIDE EITHER (1) COVER (E.G. A TARP, PLASTIC SHEETING, TEMPORARY ROOF) TO PREVENT EXPOSURE OF WASTES TO PRECIPITATION, OR (2) A SIMILAR EFFECTIVE MEANS DESIGNED TO PREVENT THE DISCHARGE OF POLLUTANTS (E.G. SECONDARY CONTAINMENT).
 - C. CLEAN UP AND DISPOSE OF WASTE IN DESIGNATED WASTE CONTAINERS.
 - D. CLEAN UP IMMEDIATELY IF CONTAINERS OVERFLOW.
 8. SANITARY WASTES:
 - A. POSITION PORTABLE TOILETS SO THAT THEY ARE SECURE AND WILL NOT BE TIPPED OR KNOCKED OVER, A ND LOCATED AWAY FROM WATERS OF THE STATE AND STORMWATER INLETS OR CONVEYANCES.
 9. WASHING APPLICATORS AND CONTAINERS:
 - A. WASHING APPLICATORS AND CONTAINERS USED FOR STUCCO, PAINT, CONCRETE, FORM RELEASE OILS, CURING COMPOUNDS, OR OTHER MATERIALS:
 - a) NO DISCHARGE OF THESE LIQUID WASTES IS ALLOWED IN STORM SEWERS OR WATERS OF THE STATE.
 - b) DISPOSE OF LIQUID WASTES IN ACCORDANCE WITH APPLICABLE REQUIREMENTS.
 - c) REMOVE AND DISPOSE OF HARDEN CONCRETE WASTE CONSISTENT WITH THE HANDLING OF THE OTHER CONSTRUCTION WASTES.
 - d) LOCATE ANY WASHOUT OR CLEANOUT ACTIVITIES AS FAR AWAY AS POSSIBLE FROM WATER OF THE STATE AND STORMWATER INLETS OR CONVEYANCES, AND, TO THE EXTENT FEASIBLE, DESIGNATE AREAS TO BE USED FOR THESE ACTIVITIES WITH SIGNS AND IN THE ESCP AND CONDUCT SUCK ACTIVITIES ONLY IN THESE AREAS.
 10. EMERGENCY SPILL NOTIFICATION REQUIREMENTS:
 - A. DISCHARGES OF TOXIC OR HAZARDOUS SUBSTANCES FROM A SPILL OR OTHER RELEASE ARE PROHIBITED. WHERE A LEAK, SPILL, OR OTHER RELEASE CONTAINING A HAZARDOUS SUBSTANCE OR OIL OCCURS DURING A 24-HOUR PERIOD, THE REGISTRANT MUST NOTIFY THE OREGON EMERGENCY RESPONSE SYSTEM AT (800) 452-0311 AS SOON AS THE REGISTRANT HAS KNOWLEDGE OF THE RELEASE. CONTACT INFORMATION MUST BE IN LOCATIONS THAT ARE READILY ACCESSIBLE AND AVAILABLE TO ALL EMPLOYEES.

PROJECT NO.:	BY:	DESCRIPTION:	DATE:	REV.:
DRAWN BY:				
DESIGN BY:				
REVIEWED BY:				
DATE:				

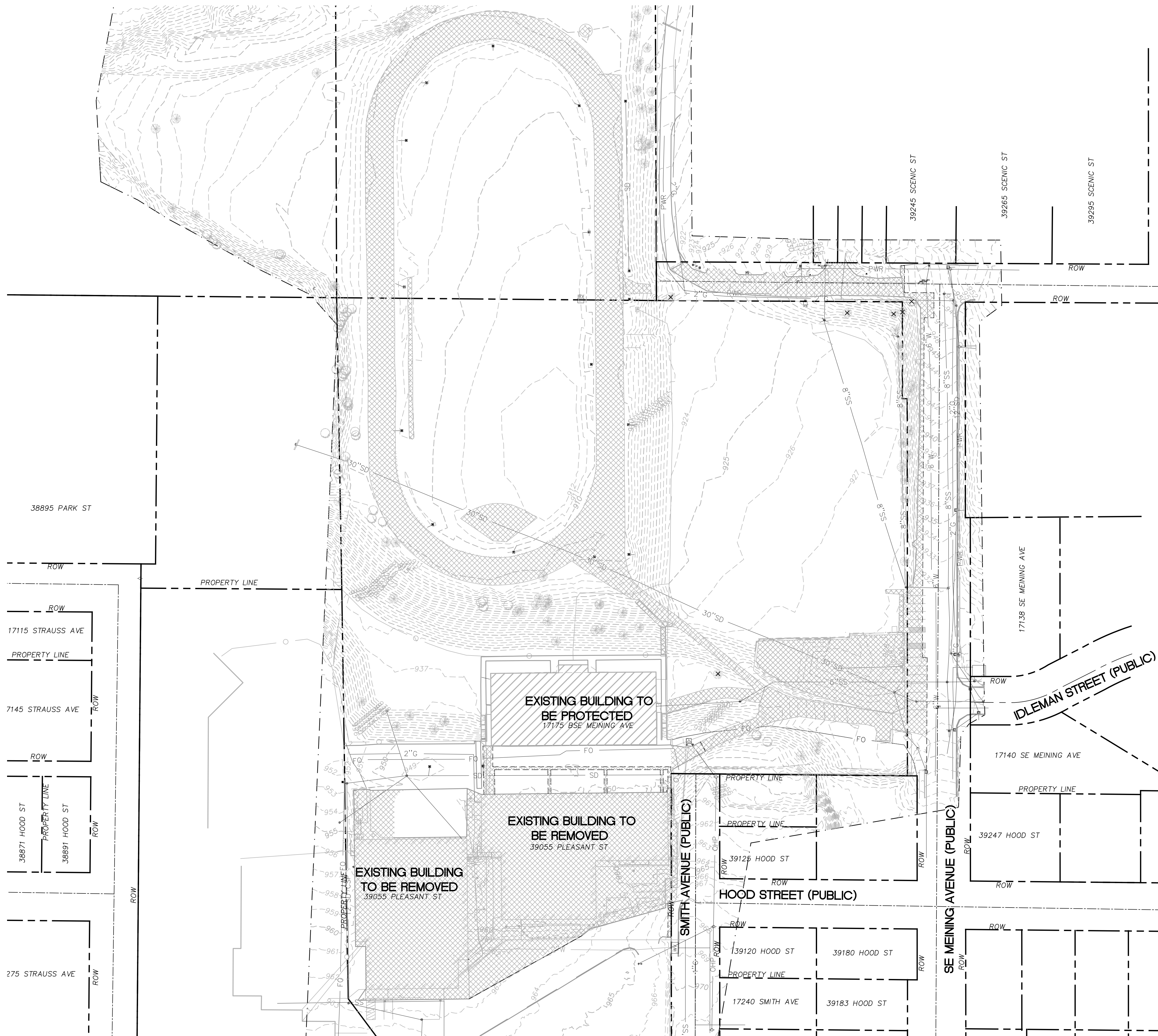

SHEET LEGEND		
ITEM	DESCRIPTION	REFERENCE
- - - 949 - - -	EXISTING CONTOUR	
[Cross-hatched box]	DEMOLISH EXISTING ASPHALT, CONCRETE AND STRUCTURES	

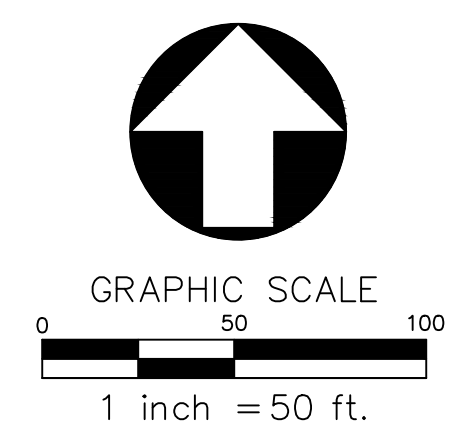

OVERALL SITE PLAN
SCALE: 1"=50'

REV	DATE	DESCRIPTION	BY



SHEET LEGEND		
ITEM	DESCRIPTION	REFERENCE
- - - 944 - - -	EXISTING CONTOUR	
○	SEDIMENT FENCE	2 C6.11
▢ (with grid pattern)	CONCRETE WASHOUT	4 C6.11
▢ (with dots)	TEMPORARY CONSTRUCTION ENTRANCE	1 C6.11
▢ (with diagonal lines)	STOCKPILE	3 C6.11
→ (with wavy line)	DRAINAGE FLOW DIRECTION	
▢ (with grid pattern)	FILTER FABRIC INLET PROTECTION	5 C6.11
✕	DEMO EXISTING TREE	

- SHEET NOTES**
- LIST OF POTENTIAL POLLUTANTS:
 - FUEL (GASOLINE/DIESEL)
 - SEDIMENT (VIA CONSTRUCTION FILL AND GRADING ACTIVITIES, STOCKPILES, VEHICLE TRACKING WIND/RAIN EROSION)
 - CONCRETE WASTE (FROM PLACEMENT OR SPILLS/LEAKS FROM WASHOUT AREAS)
 - FERTILIZERS, PESTICIDES, PAINTS, CAULKS, SEALANTS, FLUORESCENT LIGHT BALLASTS, CONTAMINATED SUBSTRATES, AND SOLVENTS.
 - TO PREVENT OFF-SITE TRACKING OF SOIL VIA VEHICLES AND EQUIPMENT, USE LIMITED ENTRANCES/EXITS, SPECIFIED ON-SITE TRUCK ROUTES, AND GRAVEL PADS AND ROADWAYS WHENEVER POSSIBLE. PHYSICALLY REMOVE SOIL FROM VEHICLES AND USE A WHEEL WASH AREA IF NECESSARY. BEFORE LEAVING THE PROPERTY, ALL VEHICLES WILL BE INSPECTED BY THEIR OCCUPANTS FOR ADHERED SOIL. SOIL WITH FREE WATER WILL NOT BE LOADED INTO TRUCKS. ALL TRUCKS WILL BE APPROPRIATELY COVERED AND SECURED BEFORE LEAVING THE SITE.
 - DUST CONTROL MEASURES SHOULD BE IMPLEMENTED AS NECESSARY.
 - ALL STOCKPILES AND BMPs ARE TO BE PROTECTED DURING PERIODS OF INACTIVITY.
 - SPILL PREVENTION PROCEDURE INCLUDES UTILIZING CONTAINMENT FACILITIES, DEPLOY SPILL KIT, PROPER REMOVAL AND DISPOSAL OF CONTAMINATES PER DEQ REGULATIONS AND GUIDELINES.
 - LIST OF AUTHORIZED NON-STORMWATER DISCHARGES:
 - PROPERTY MANAGED LANDSCAPED IRRIGATION.
 - WATER USED TO WASH EQUIPMENT AND VEHICLES (EXCLUDING THE ENGINE, UNDERCARRIAGE, AND WHEELS/TIRES) PROVIDED THERE IS NO DISCHARGE OF SOAPS, SOLVENTS OR DETERGENTS USED.
 - WATER USED TO CONTROL DUST.

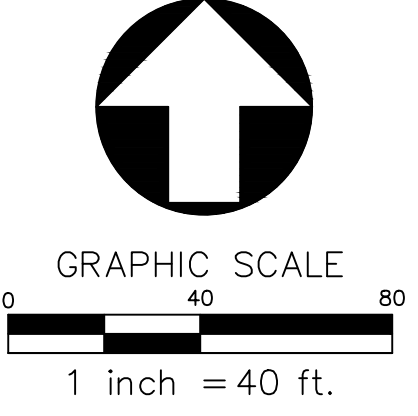



Humber
Design
Group, Inc.
Civil Engineering • 503.946.6690 • hdpdx.com

CLEARING AND DEMOLITION ESC PLAN-PARK

SANDY COMMUNITY BUILDING DEMO

CITY OF SANDY
39250 PIONEER BOULEVARD SANDY OR 97055

BY: MCS
DESCRIPTION: ADDENDUM 5
DATE: 11/29/2023

PROJECT NO.:
DRAWN BY:
DESIGN BY:
REVIEWED BY:
DATE:

SHEET NO.

C6.04

P:\COS001 - Cedar Ridge Demo7 - CAD Drawings\COS001 - C6.00 - 1200C Plans - LAN004 - 1200C.dwg Nov 30, 2023 - 10:18am

REV	DATE	DESCRIPTION	BY
2	11/29/2023	ADDENDUM 5	MCS

PROJECT NO.:	DRAWN BY:	DESIGN BY:	REVIEWED BY:	DATE:

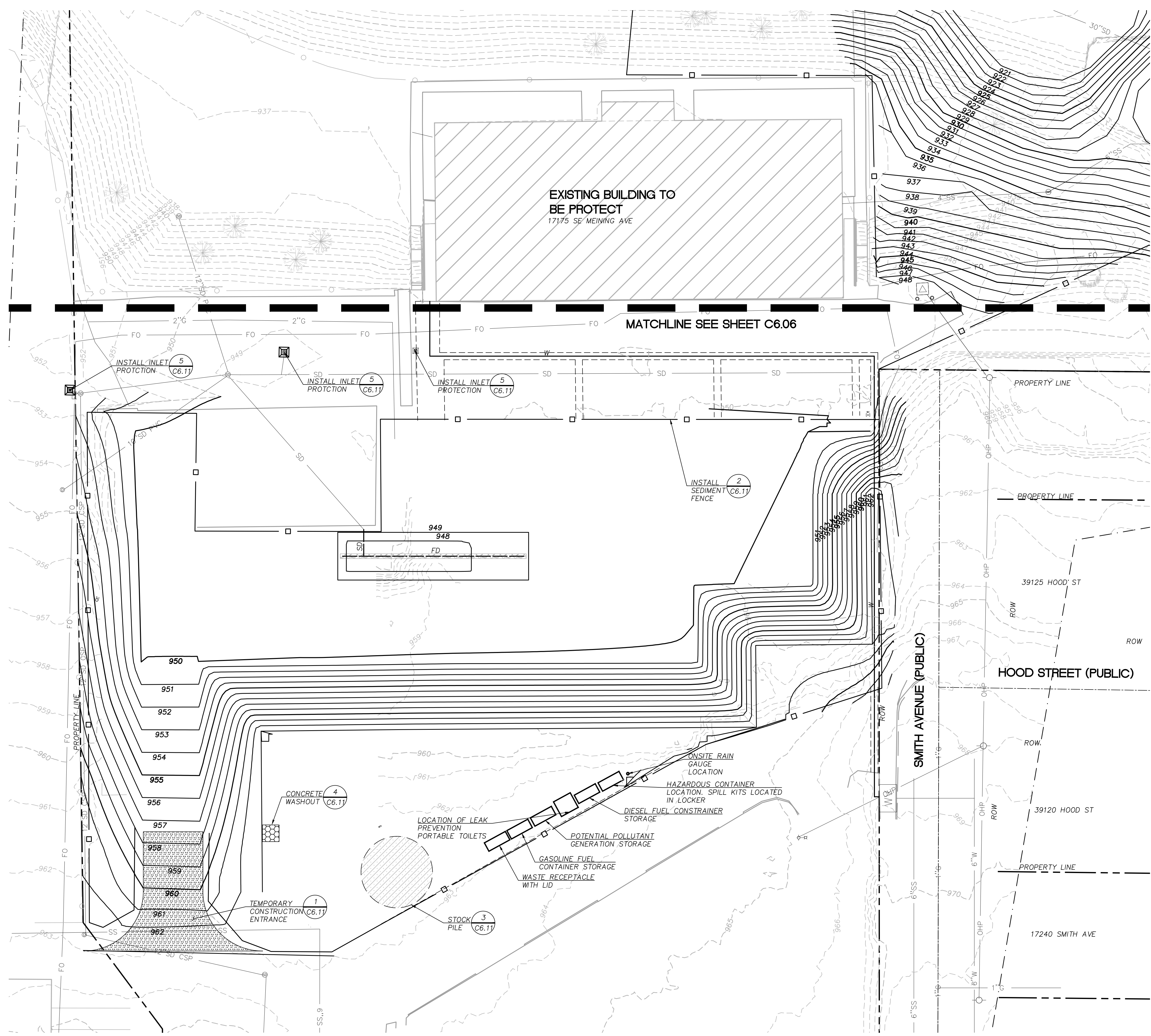

SHEET LEGEND		
ITEM	DESCRIPTION	REFERENCE
---	EXISTING CONTOUR	
949	PROPOSED CONTOUR	
□	SEDIMENT FENCE	(2) C6.11
▒	CONCRETE WASHOUT	(4) C6.11
▒	TEMPORARY CONSTRUCTION ENTRANCE	(1) C6.11
▒	STOCKPILE	(3) C6.11
□	FILTER FABRIC INLET PROTECTION	(5) C6.11

- SHEET NOTES**
- LIST OF POTENTIAL POLLUTANTS:
 - FUEL (GASOLINE/DIESEL)
 - SEDIMENT (VIA CONSTRUCTION FILL AND GRADING ACTIVITIES, STOCKPILES, VEHICLE TRACKING WIND/RAIN EROSION)
 - CONCRETE WASTE (FROM PLACEMENT OR SPILLS/LEAKS FROM WASHOUT AREAS)
 - FERTILIZERS, PESTICIDES, PAINTS, CAULKS, SEALANTS, FLUORESCENT LIGHT BALLASTS, CONTAMINATED SUBSTRATES, AND SOLVENTS.
 - CUT VOLUME = 5,469 CY, FILL VOLUME = 1,419 CY
 NET CUT VOLUME = 4,050 CY
 - VOLUMES INCLUDE GRADING FOR SCHOOL DEMOLITION AND AQUATIC FACILITY ONLY. CONTRACTOR TO CONFIRM QUANTITIES.
 - IF SOIL CONTAMINATION IS SUSPECTED HALT WORK, OR REMOVE AND STOCKPILE THE SUSPECT SOILS. NOTIFY DESIGNATED ENVIRONMENTAL CONSULTANT, EITHER DISPOSE OF THE SUSPECT SOILS AT A DESIGNATED LANDFILL (ASSUMING SOILS HAVE BEEN PRE-APPROVED FOR ACCEPTANCE) OR TEST THE IN-PLACE OR STOCKPILED SOILS TO CHARACTERIZE AND DETERMINE AN APPROPRIATE DISPOSAL LOCATION. IF FREE PRODUCT (NON-AQUEOUS PHASE LIQUID) IS ENCOUNTERED, NOTIFY DEQ WITHIN 48 HOURS OF DISCOVERY.
 - TO PREVENT OFF-SITE TRACKING OF SOIL VIA VEHICLES AND EQUIPMENT, USE LIMITED ENTRANCES/EXITS, SPECIFIED ON-SITE TRUCK ROUTES, AND GRAVEL PADS AND ROADWAYS WHENEVER POSSIBLE. PHYSICALLY REMOVE SOIL FROM VEHICLES AND USE A WHEEL WASH AREA IF NECESSARY. BEFORE LEAVING THE PROPERTY, ALL VEHICLES WILL BE INSPECTED BY THEIR OCCUPANTS FOR ADHERED SOIL. SOIL WITH FREE WATER WILL NOT BE LOADED INTO TRUCKS. ALL TRUCKS WILL BE APPROPRIATELY COVERED AND SECURED BEFORE LEAVING THE SITE.
 - DUST CONTROL MEASURES SHOULD BE IMPLEMENTED AS NECESSARY.
 - ALL STOCKPILES AND BMPs ARE TO BE PROTECTED DURING PERIODS OF INACTIVITY.
 - SPILL PREVENTION PROCEDURE INCLUDES UTILIZING CONTAINMENT FACILITIES, DEPLOY SPILL KIT, PROPER REMOVAL AND DISPOSAL OF CONTAMINATES PER DEQ REGULATIONS AND GUIDELINES.
 - LIST OF AUTHORIZED NON-STORMWATER DISCHARGES:
 - PROPERTY MANAGED LANDSCAPED IRRIGATION.
 - WATER USED TO WASH EQUIPMENT AND VEHICLES (EXCLUDING THE ENGINE, UNDERCARRIAGE, AND WHEELS/TIRES) PROVIDED THERE IS NO DISCHARGE OF SOAPS, SOLVENTS OR DETERGENTS USED.
 - WATER USED TO CONTROL DUST.

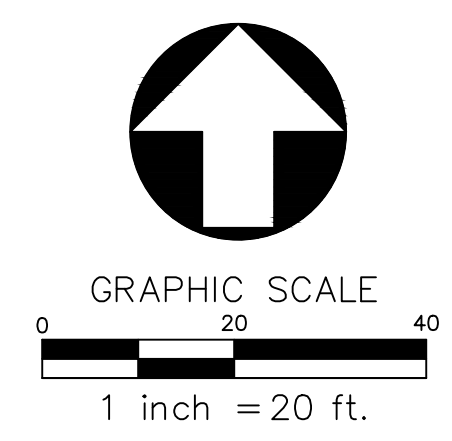

MASS GRADING AND UTILITY ESC PLAN-SCHOOL
 SCALE: 1" = 20'



SHEET LEGEND		
ITEM	DESCRIPTION	REFERENCE
---949---	EXISTING CONTOUR	
949	PROPOSED CONTOUR	
○	SEDIMENT FENCE	2 C6.11
▒	CONCRETE WASHOUT	4 C6.11
▒	TEMPORARY CONSTRUCTION ENTRANCE	1 C6.11
▒	STOCKPILE	3 C6.11
□	FILTER FABRIC INLET PROTECTION	5 C6.11

- SHEET NOTES**
- LIST OF POTENTIAL POLLUTANTS:
 - FUEL (GASOLINE/DIESEL)
 - SEDIMENT (VIA CONSTRUCTION FILL AND GRADING ACTIVITIES, STOCKPILES, VEHICLE TRACKING WIND/RAIN EROSION)
 - CONCRETE WASTE (FROM PLACEMENT OR SPILLS/LEAKS FROM WASHOUT AREAS)
 - FERTILIZERS, PESTICIDES, PAINTS, CAULKS, SEALANTS, FLUORESCENT LIGHT BALLASTS, CONTAMINATED SUBSTRATES, AND SOLVENTS.
 - CUT VOLUME = 9,618 CY, FILL VOLUME = 13,335 CY
NET CUT VOLUME = 4,050 CY
- VOLUMES INCLUDE GRADING FOR PARK PROJECT ONLY. CONTRACTOR TO CONFIRM QUANTITIES.
 - IF SOIL CONTAMINATION IS SUSPECTED HALT WORK, OR REMOVE AND STOCKPILE THE SUSPECT SOILS, NOTIFY DESIGNATED ENVIRONMENTAL CONSULTANT, EITHER DISPOSE OF THE SUSPECT SOILS AT A DESIGNATED LANDFILL (ASSUMING SOILS HAVE BEEN PRE-APPROVED FOR ACCEPTANCE) OR TEST THE IN-PLACE OR STOCKPILED SOILS TO CHARACTERIZE AND DETERMINE AN APPROPRIATE DISPOSAL LOCATION. IF FREE PRODUCT (NON-AQUEOUS PHASE LIQUID) IS ENCOUNTERED, NOTIFY DEQ WITHIN 48 HOURS OF DISCOVERY.
 - TO PREVENT OFF-SITE TRACKING OF SOIL VIA VEHICLES AND EQUIPMENT, USE LIMITED ENTRANCES/EXITS, SPECIFIED ON-SITE TRUCK ROUTES, AND GRAVEL PADS AND ROADWAYS WHENEVER POSSIBLE. PHYSICALLY REMOVE SOIL FROM VEHICLES AND USE A WHEEL WASH AREA IF NECESSARY. BEFORE LEAVING THE PROPERTY, ALL VEHICLES WILL BE INSPECTED BY THEIR OCCUPANTS FOR ADHERED SOIL. SOIL WITH FREE WATER WILL NOT BE LOADED INTO TRUCKS. ALL TRUCKS WILL BE APPROPRIATELY COVERED AND SECURED BEFORE LEAVING THE SITE.
 - DUST CONTROL MEASURES SHOULD BE IMPLEMENTED AS NECESSARY.
 - ALL STOCKPILES AND BMPs ARE TO BE PROTECTED DURING PERIODS OF INACTIVITY.
 - SPILL PREVENTION PROCEDURE INCLUDES UTILIZING CONTAINMENT FACILITIES, DEPLOY SPILL KIT, PROPER REMOVAL AND DISPOSAL OF CONTAMINATES PER DEQ REGULATIONS AND GUIDELINES.
 - LIST OF AUTHORIZED NON-STORMWATER DISCHARGES:
 - PROPERTY MANAGED LANDSCAPED IRRIGATION.
 - WATER USED TO WASH EQUIPMENT AND VEHICLES (EXCLUDING THE ENGINE, UNDERCARRIAGE, AND WHEELS/TIRES) PROVIDED THERE IS NO DISCHARGE OF SOAPS, SOLVENTS OR DETERGENTS USED.
 - WATER USED TO CONTROL DUST.

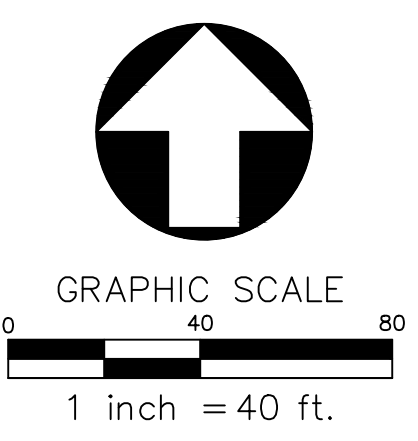

REV.	DATE	DESCRIPTION	BY

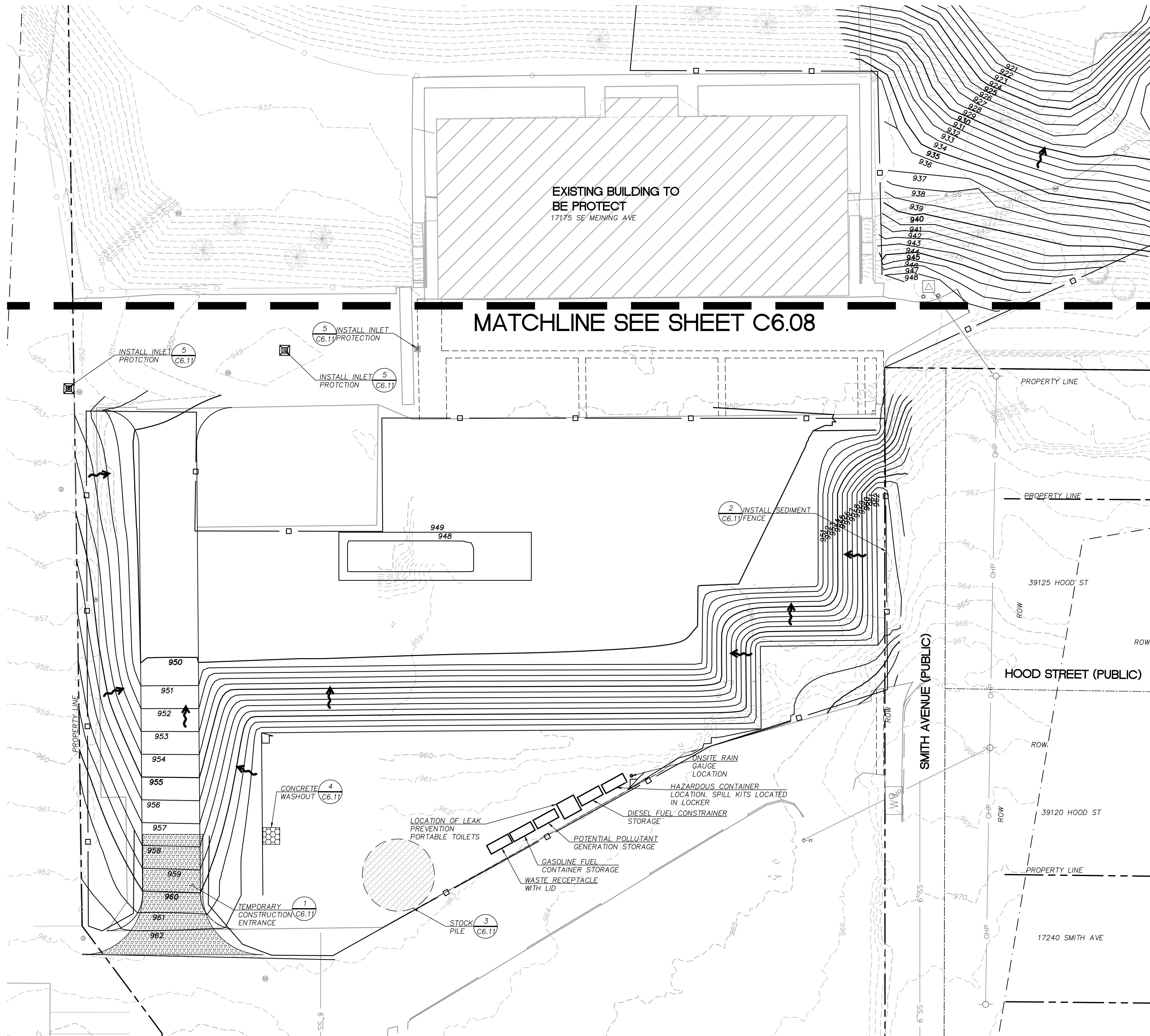

SHEET LEGEND		
ITEM	DESCRIPTION	REFERENCE
- - - 944 - - -	EXISTING CONTOUR	
949	PROPOSED CONTOUR	
○	SEDIMENT FENCE	(2) C6.11
▒	CONCRETE WASHOUT	(4) C6.11
▒	TEMPORARY CONSTRUCTION ENTRANCE	(1) C6.11
▒	STOCKPILE	(3) C6.11
→	DRAINAGE FLOW DIRECTION	
□	FILTER FABRIC INLET PROTECTION	(5) C6.11

- SHEET NOTES**
- LIST OF POTENTIAL POLLUTANTS:
 - FUEL (GASOLINE/DIESEL)
 - SEDIMENT (VIA CONSTRUCTION FILL AND GRADING ACTIVITIES, STOCKPILES, VEHICLE TRACKING WIND/RAIN EROSION)
 - CONCRETE WASTE (FROM PLACEMENT OR SPILLS/LEAKS FROM WASHOUT AREAS)
 - FERTILIZERS, PESTICIDES, PAINTS, CAULKS, SEALANTS, FLUORESCENT LIGHT BALLASTS, CONTAMINATED SUBSTRATES, AND SOLVENTS.
 - TO PREVENT OFF-SITE TRACKING OF SOIL VIA VEHICLES AND EQUIPMENT, USE LIMITED ENTRANCES/EXITS, SPECIFIED ON-SITE TRUCK ROUTES, AND GRAVEL PADS AND ROADWAYS WHENEVER POSSIBLE. PHYSICALLY REMOVE SOIL FROM VEHICLES AND USE A WHEEL WASH AREA IF NECESSARY. BEFORE LEAVING THE PROPERTY, ALL VEHICLES WILL BE INSPECTED BY THEIR OCCUPANTS FOR ADHERED SOIL. SOIL WITH FREE WATER WILL NOT BE LOADED INTO TRUCKS. ALL TRUCKS WILL BE APPROPRIATELY COVERED AND SECURED BEFORE LEAVING THE SITE.
 - DUST CONTROL MEASURES SHOULD BE IMPLEMENTED AS NECESSARY.
 - ALL STOCKPILES AND BMPs ARE TO BE PROTECTED DURING PERIODS OF INACTIVITY.
 - SPILL PREVENTION PROCEDURE INCLUDES UTILIZING CONTAINMENT FACILITIES, DEPLOY SPILL KIT, PROPER REMOVAL AND DISPOSAL OF CONTAMINATES PER DEQ REGULATIONS AND GUIDELINES.
 - LIST OF AUTHORIZED NON-STORMWATER DISCHARGES:
 - PROPERTY MANAGED LANDSCAPED IRRIGATION.
 - WATER USED TO WASH EQUIPMENT AND VEHICLES (EXCLUDING THE ENGINE, UNDERCARRIAGE, AND WHEELS/TIRES) PROVIDED THERE IS NO DISCHARGE OF SOAPS, SOLVENTS OR DETERGENTS USED.
 - WATER USED TO CONTROL DUST.

VERTICAL CONSTRUCTION ESC PLAN-SCHOOL
SCALE: 1"=20'

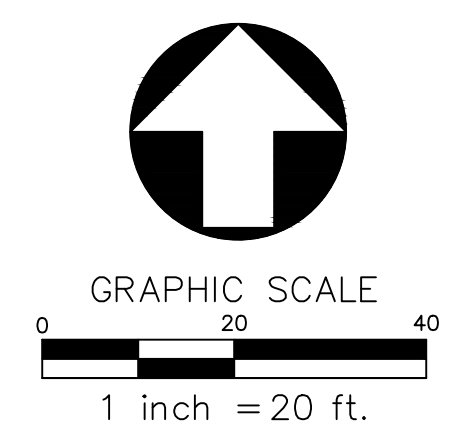

REV	DATE	DESCRIPTION	BY

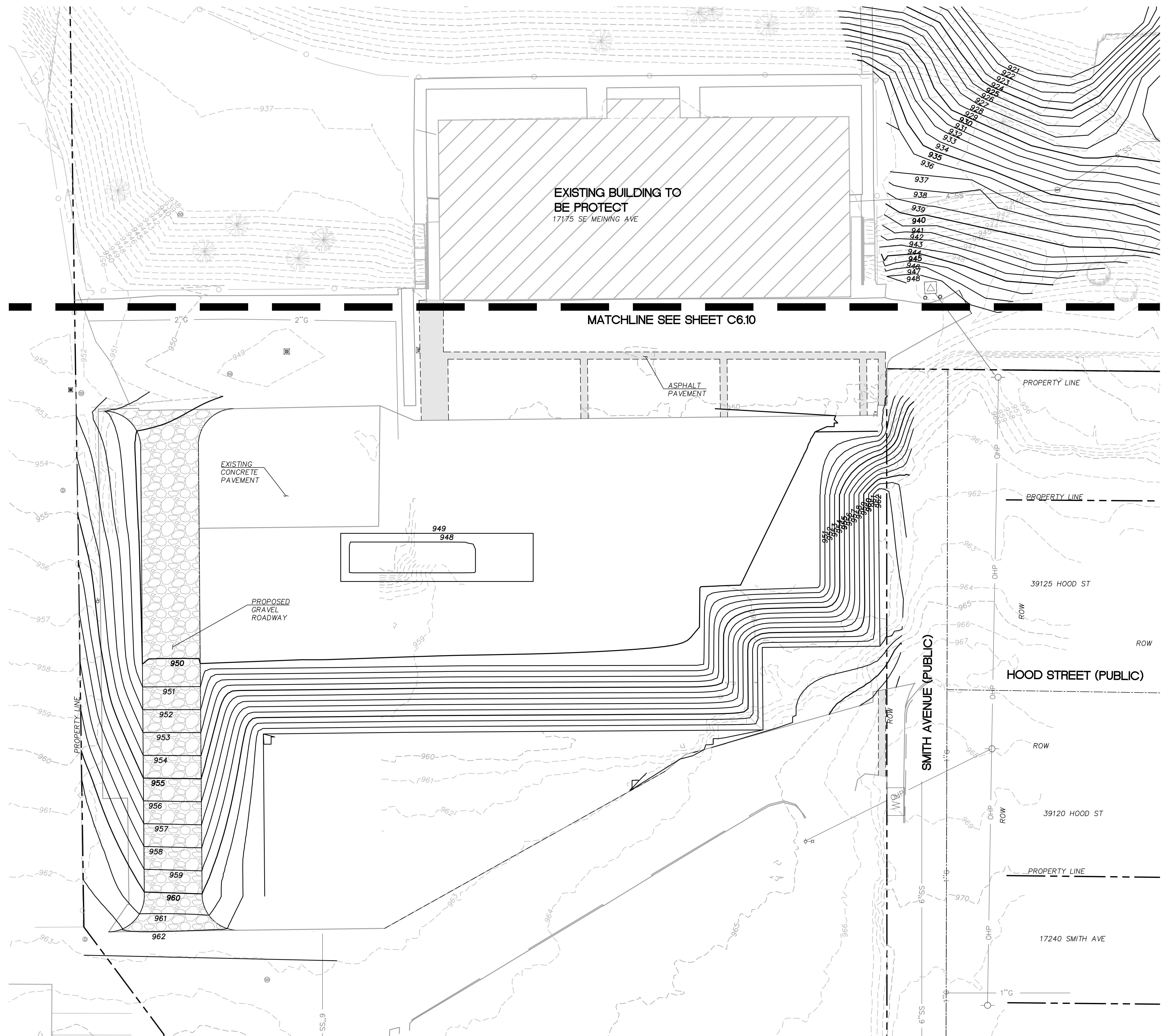

SHEET LEGEND		
ITEM	DESCRIPTION	REFERENCE
-949-	EXISTING CONTOUR	
949	PROPOSED CONTOUR	

- SHEET NOTES**
- LIST OF POTENTIAL POLLUTANTS:
 - FUEL (GASOLINE/DIESEL)
 - SEDIMENT (VIA CONSTRUCTION FILL AND GRADING ACTIVITIES, STOCKPILES, VEHICLE TRACKING WIND/RAIN EROSION)
 - CONCRETE WASTE (FROM PLACEMENT OR SPILLS/LEAKS FROM WASHOUT AREAS)
 - FERTILIZERS, PESTICIDES, PAINTS, CAULKS, SEALANTS, FLUORESCENT LIGHT BALLASTS, CONTAMINATED SUBSTRATES, AND SOLVENTS.
 - ALL PERIMETER SEDIMENT FENCING AND INLET PROTECTION TO BE REMOVED UPON COMPLETION OF THIS PEACHES.
 - TO PREVENT OFF-SITE TRACKING OF SOIL VIA VEHICLES AND EQUIPMENT, USE LIMITED ENTRANCES/EXITS, SPECIFIED ON-SITE TRUCK ROUTES, AND GRAVEL PADS AND ROADWAYS WHENEVER POSSIBLE. PHYSICALLY REMOVE SOIL FROM VEHICLES AND USE A WHEEL WASH AREA IF NECESSARY. BEFORE LEAVING THE PROPERTY, ALL VEHICLES WILL BE INSPECTED BY THEIR OCCUPANTS FOR ADHERED SOIL. SOIL WITH FREE WATER WILL NOT BE LOADED INTO TRUCKS. ALL TRUCKS WILL BE APPROPRIATELY COVERED AND SECURED BEFORE LEAVING THE SITE.
 - DUST CONTROL MEASURES SHOULD BE IMPLEMENTED AS NECESSARY.
 - ALL STOCKPILES AND BMPs ARE TO BE PROTECTED DURING PERIODS OF INACTIVITY.
 - SPILL PREVENTION PROCEDURE INCLUDES UTILIZING CONTAINMENT FACILITIES, DEPLOY SPILL KIT, PROPER REMOVAL AND DISPOSAL OF CONTAMINATES PER DEQ REGULATIONS AND GUIDELINES.
 - LIST OF AUTHORIZED NON-STORMWATER DISCHARGES:
 - PROPERTY MANAGED LANDSCAPED IRRIGATION.
 - WATER USED TO WASH EQUIPMENT AND VEHICLES (EXCLUDING THE ENGINE, UNDERCARRIAGE, AND WHEELS/TIRES) PROVIDED THERE IS NO DISCHARGE OF SOAPS, SOLVENTS OR DETERGENTS USED.
 - WATER USED TO CONTROL DUST.

FINAL STABILIZATION PLAN-SCHOOL
SCALE: 1" = 20'

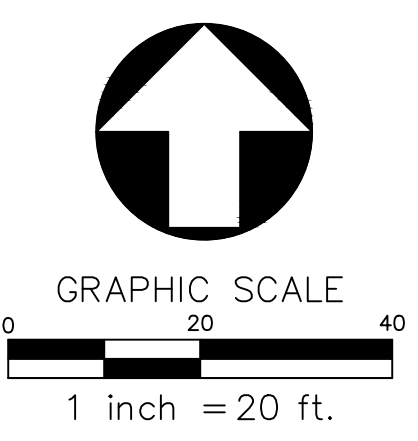

Humber Design Group, Inc.



FINAL STABILIZATION PLAN-SCHOOL
SANDY COMMUNITY BUILDING DEMO
CITY OF SANDY
39250 PIONEER BOULEVARD SANDY OR 97055

REV	DATE	DESCRIPTION	BY

PROJECT NO.:	
DRAWN BY:	
DESIGN BY:	
REVIEWED BY:	
DATE:	

SHEET NO.
C6.09

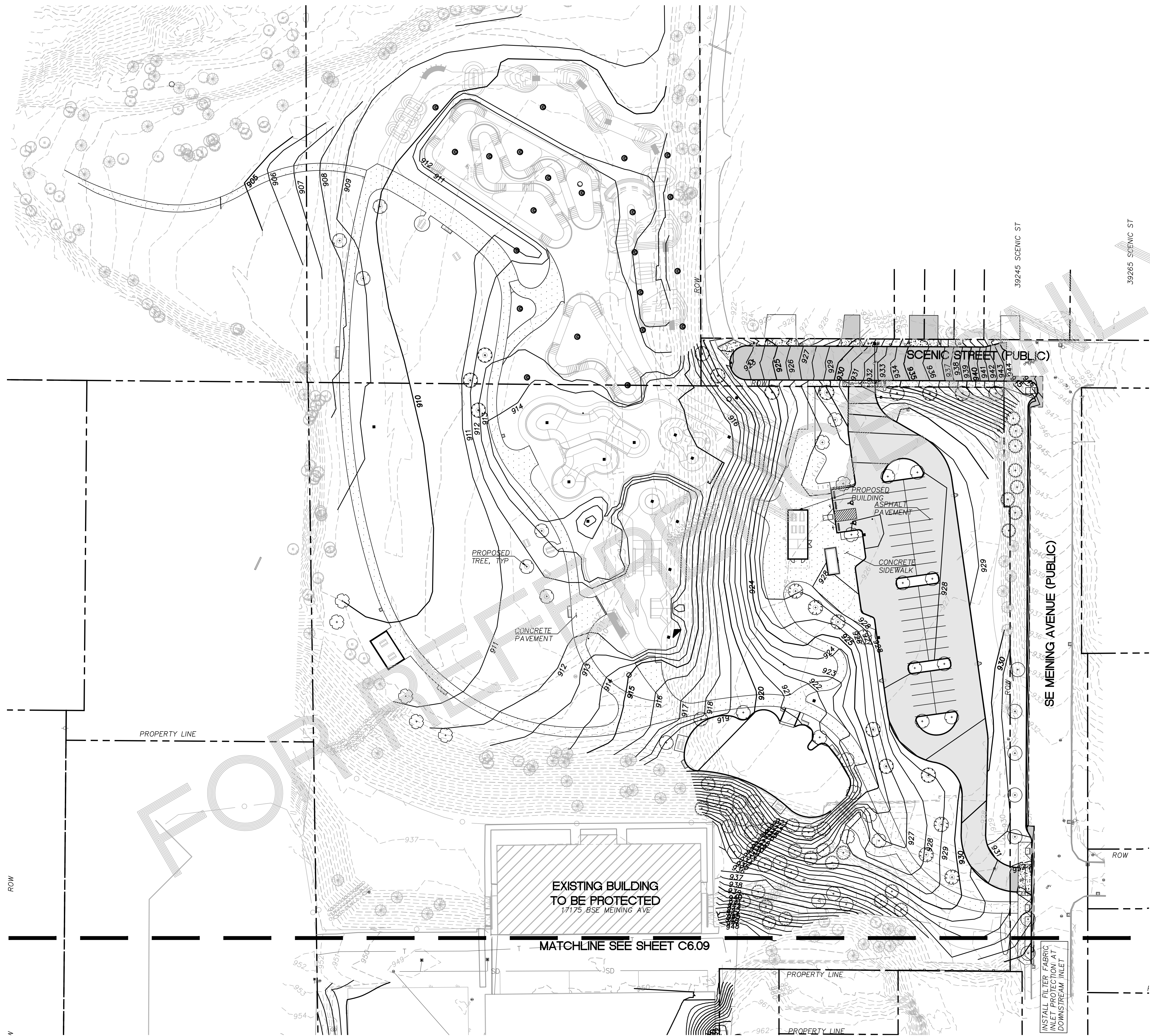

SHEET LEGEND		
ITEM	DESCRIPTION	REFERENCE
- - - 949 - - -	EXISTING CONTOUR	
949	PROPOSED CONTOUR	

- SHEET NOTES**
- LIST OF POTENTIAL POLLUTANTS:
 - FUEL (GASOLINE/DIESEL)
 - SEDIMENT (VIA CONSTRUCTION FILL AND GRADING ACTIVITIES, STOCKPILES, VEHICLE TRACKING WIND/RAIN EROSION)
 - CONCRETE WASTE (FROM PLACEMENT OR SPILLS/LEAKS FROM WASHOUT AREAS)
 - FERTILIZERS, PESTICIDES, PAINTS, CAULKS, SEALANTS, FLUORESCENT LIGHT BALLASTS, CONTAMINATED SUBSTRATES, AND SOLVENTS.
 - ALL PERIMETER SEDIMENT FENCING AND INLET PROTECTION TO BE REMOVED UPON COMPLETION OF THIS PEACHES.
 - TO PREVENT OFF-SITE TRACKING OF SOIL VIA VEHICLES AND EQUIPMENT, USE LIMITED ENTRANCES/EXITS, SPECIFIED ON-SITE TRUCK ROUTES, AND GRAVEL PADS AND ROADWAYS WHENEVER POSSIBLE. PHYSICALLY REMOVE SOIL FROM VEHICLES AND USE A WHEEL WASH AREA IF NECESSARY. BEFORE LEAVING THE PROPERTY, ALL VEHICLES WILL BE INSPECTED BY THEIR OCCUPANTS FOR ADHERED SOIL. SOIL WITH FREE WATER WILL NOT BE LOADED INTO TRUCKS. ALL TRUCKS WILL BE APPROPRIATELY COVERED AND SECURED BEFORE LEAVING THE SITE.
 - DUST CONTROL MEASURES SHOULD BE IMPLEMENTED AS NECESSARY.
 - ALL STOCKPILES AND BMPs ARE TO BE PROTECTED DURING PERIODS OF INACTIVITY.
 - SPILL PREVENTION PROCEDURE INCLUDES UTILIZING CONTAINMENT FACILITIES, DEPLOY SPILL KIT, PROPER REMOVAL AND DISPOSAL OF CONTAMINATES PER DEQ REGULATIONS AND GUIDELINES.
 - LIST OF AUTHORIZED NON-STORMWATER DISCHARGES:
 - PROPERTY MANAGED LANDSCAPED IRRIGATION.
 - WATER USED TO WASH EQUIPMENT AND VEHICLES (EXCLUDING THE ENGINE, UNDERCARRIAGE, AND WHEELS/TIRES) PROVIDED THERE IS NO DISCHARGE OF SOAPS, SOLVENTS OR DETERGENTS USED.
 - WATER USED TO CONTROL DUST.

Humber Design Group, Inc.



FINAL STABILIZATION PLAN-PARK
 SANDY COMMUNITY BUILDING DEMO
 CITY OF SANDY
 39250 PIONEER BOULEVARD SANDY OR 97055

REV	DATE	DESCRIPTION	BY

SHEET NO.
C6.10

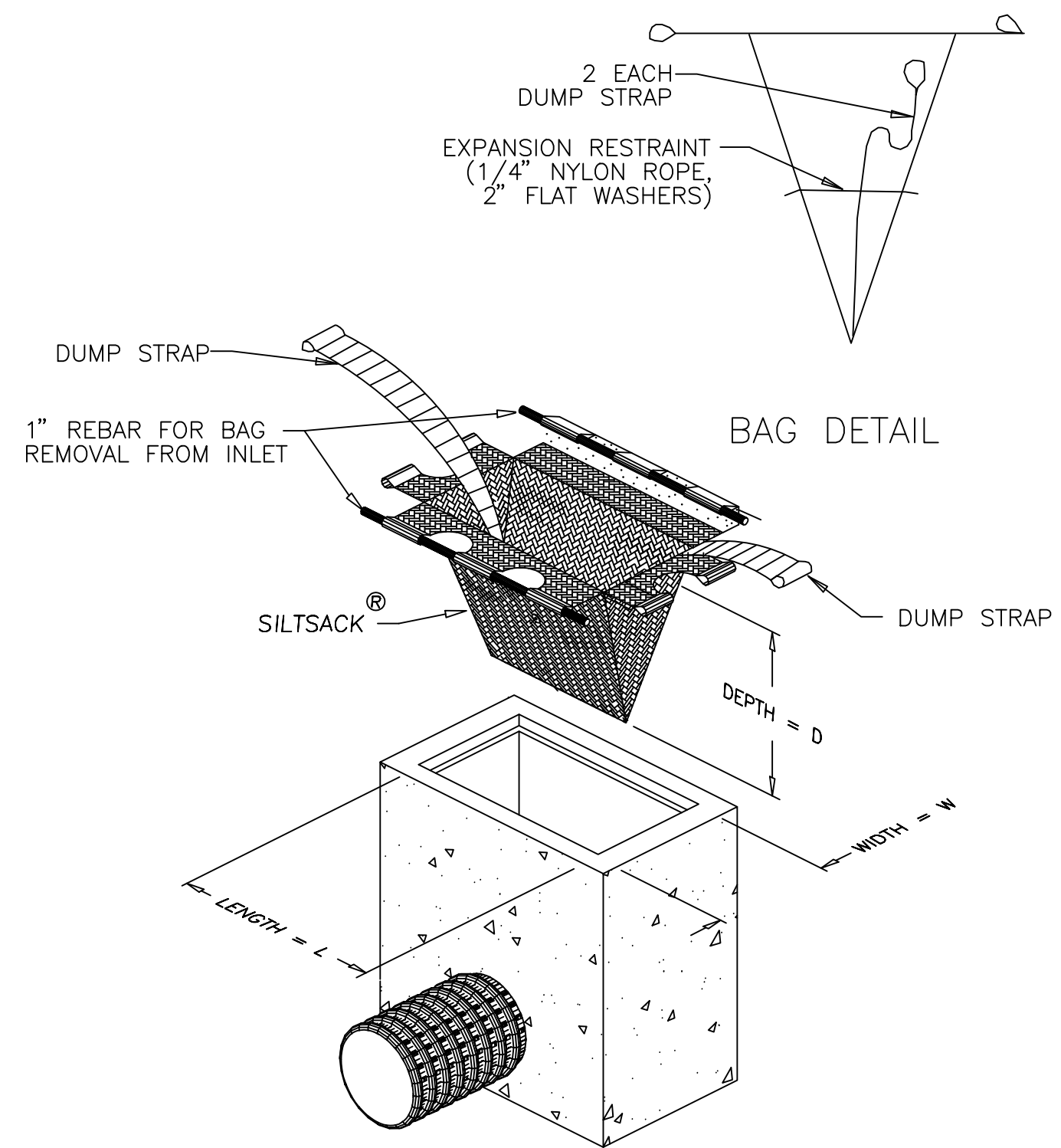

***REGULAR FLOW ONLY. DO NOT USE HIGH FLOW INSERT BAGS.

NOTES:
1. INSERT SACKS MUST BE REMOVED AT THE END OF CONSTRUCTION

5 FILTER FABRIC INLET PROTECTION
NTS

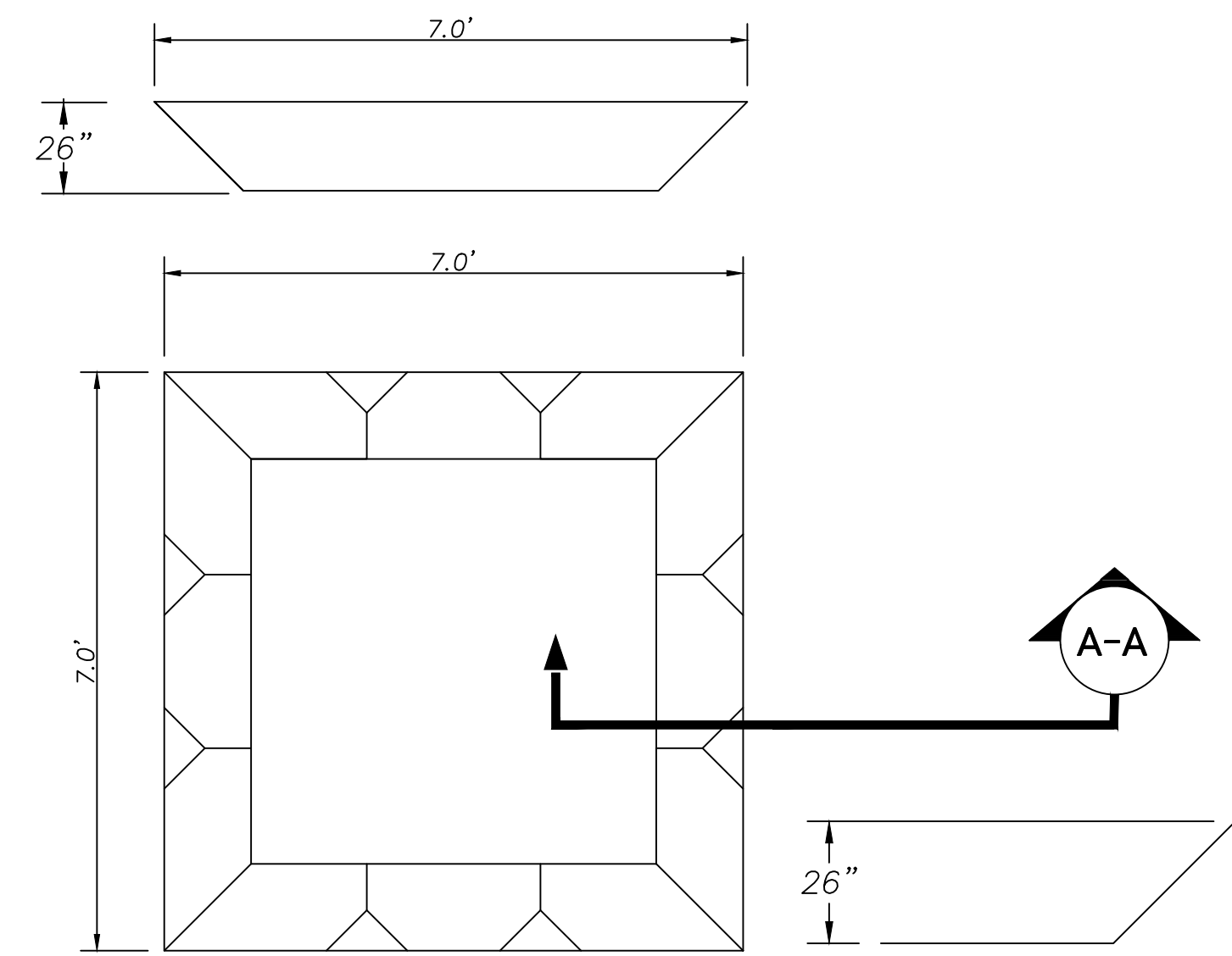

SECTION A-A
NTS

NOTE:
1. 7'X7'X26\", 600 GALLON CAPACITY ECO PAN AS MANUFACTURED BY ECO-PAN(R), OR APPROVED EQUAL.

4 CONCRETE TRUCK CHUTE WASHOUT
NTS

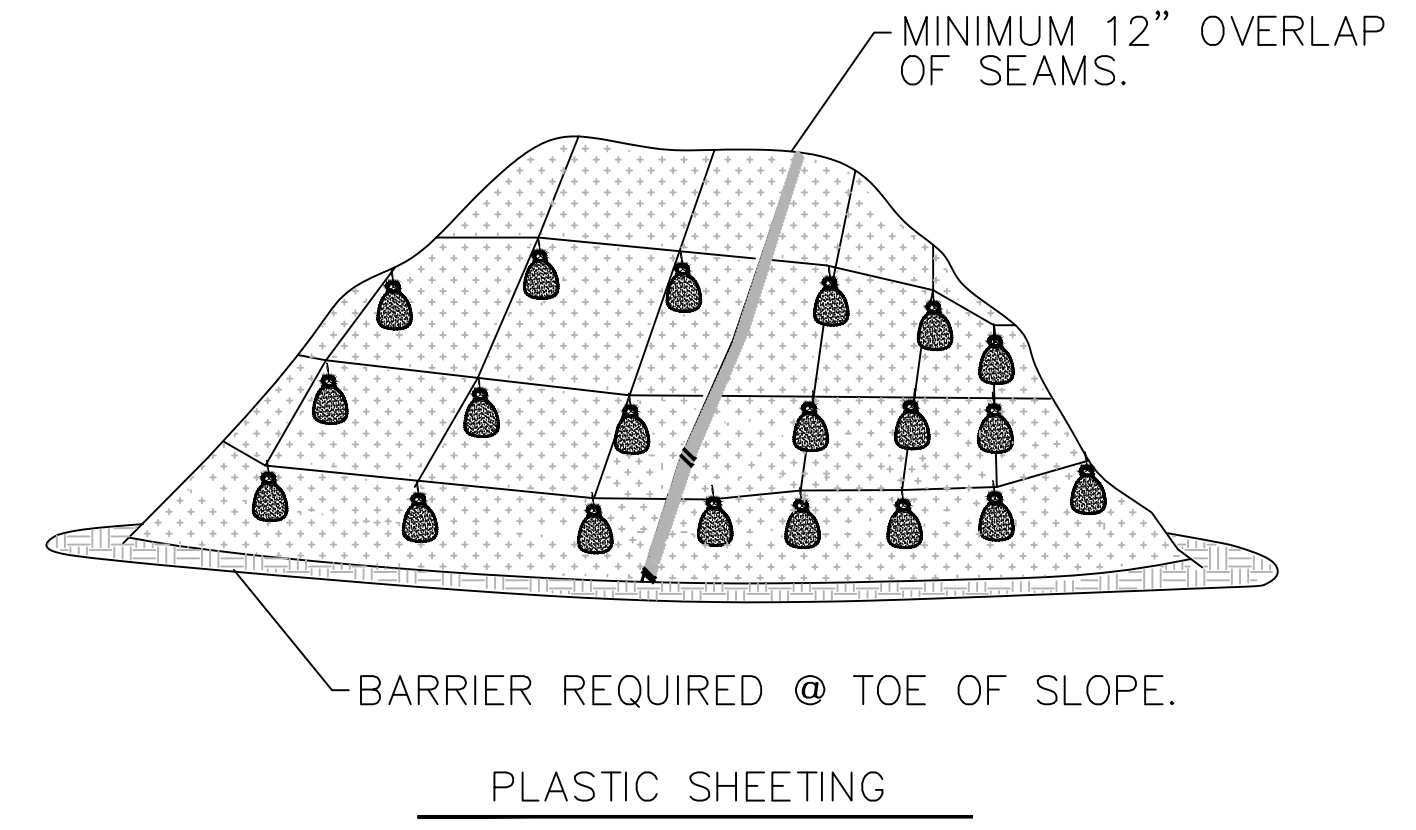

NOTES:
1. MINIMUM 12\"/>

3 STOCK PILE - PLASTIC SHEETING
NTS

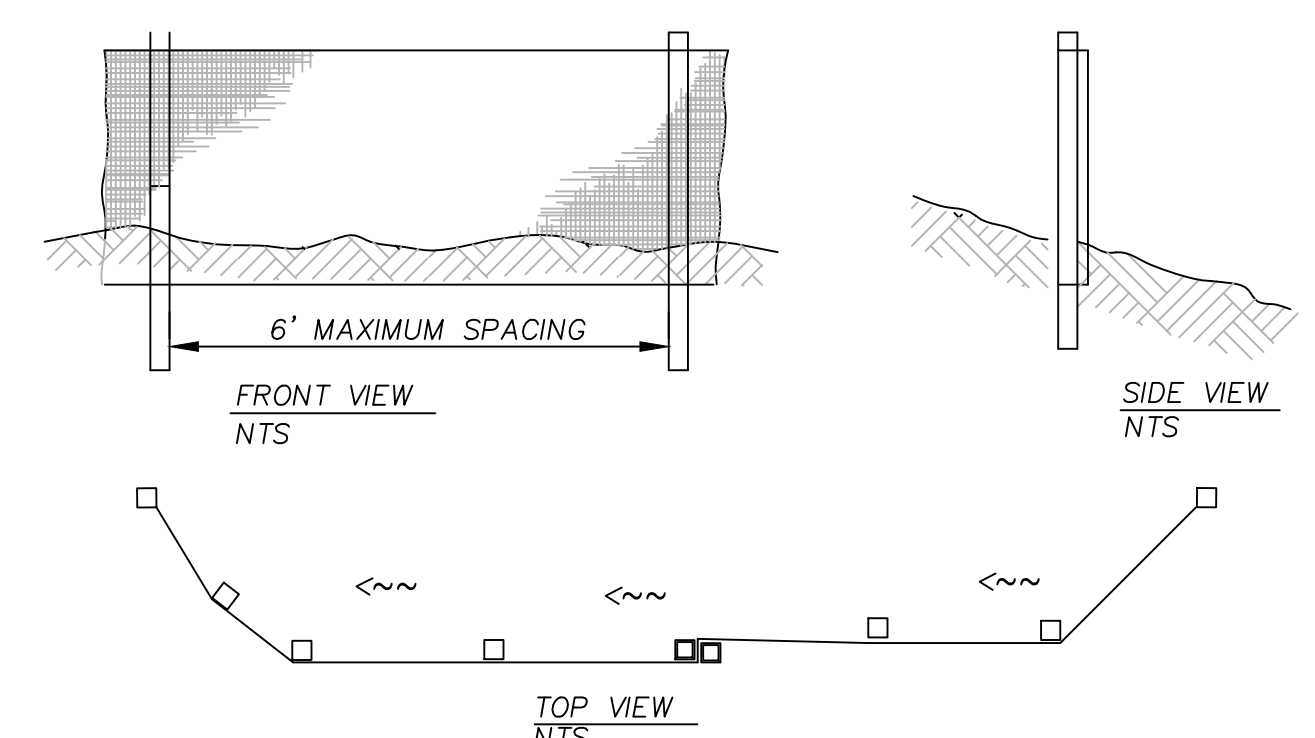

NOTES:
1. BURY BOTTOM OF FILTER FABRIC 6\"/>

2 SEDIMENT FENCE
NTS

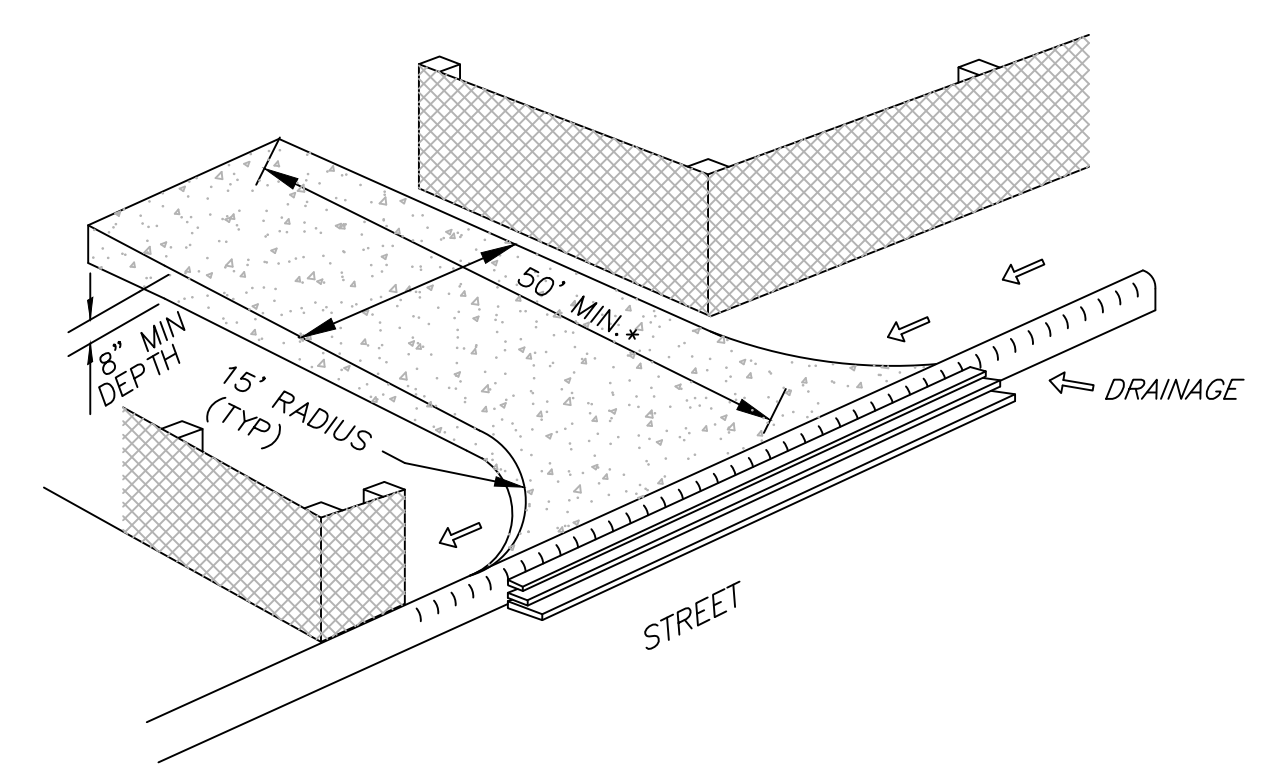

*20' MIN. FOR SINGLE FAMILY AND DUPLEX RESIDENTIAL

1 TEMPORARY CONSTRUCTION ENTRANCE
NTS

REV	DATE	DESCRIPTION	BY

SHEET NO.

C6.11