

EXHIBIT D

Preliminary Storm Drainage Design and Calculations For the Bull Run Terrace Subdivision

November 20, 2019

Prepared By:

All County Surveyors and Planners, Inc.
Tyler Henderson, E.I.
Ray L. Moore, P.E., P.L.S.
P.O. Box 955
Sandy, Oregon 97055
Phone: (503) 668-3151
Job #19-035

Prepared For:

Roll Tide Properties Corporation
Alex Reverman
P.O. Box 703
Cornelius, OR 97113
Phone: (503) 327-6084



RENEWAL DATE: 12/31/2020

Table of Contents:

Page(s)

Table of Contents and Appendices.....	1
Purpose.....	2
Project Location and Description	2
Proposed Improvements	2
Hydrograph Parameters	3-4
Detention Sizing Results	5
Water Quality Design	6
Conclusions	6

Appendices:

Appendix A

- Vicinity Map
- Site Layout
- Pre-Developed Areas
- Developed Areas

Appendix B

- Standard Formulas
- Coefficients
- SCS Runoff Curve Numbers (CN)
- Hydrograph Analysis Summary
- Detention System Summary
- Stage Storage Summary
- Rectangular, Sharp Crested Weir Calculations
- Contech CDS2015-4-C Detail

PURPOSE:

The purpose of this analysis is to:

- Describe existing and proposed site conditions.
- Provide detention calculations for the 2-yr, 5-yr, 10-yr, and 25-yr storm events.
- Provide water quality calculations.

PROJECT LOCATION AND DESCRIPTION:

The project site is located on the south side of the Mount Hood Highway in Sandy, Oregon. The site includes tax lots 900 and 1000. The +/- 15.9-acre site consists of grassy fields, and plentiful tree cover. The land is generally sloped to the north and west with an average slope of about 8%. A Vicinity Map and Site Layout (with proposed storm sewer layout) can be found in Appendix A.

PROPOSED IMPROVEMENTS

The proposed 7-lot Bull Run Terrace Subdivision project will consist of four single-family residential lots ranging from 5,748 SF to 7,444 SF. The project will also include three multi-family lots ranging in size from 52,667 SF to 292,076 SF. The site improvements will include streets, curbs, sidewalks, utilities, etc.

New storm sewer pipes, manholes, and catch basins will be installed to convey storm water to a public detention pond located in Tract B. A new water quality manhole will be installed downstream of the detention pond (See Site Layout – Appendix A).

The pond will be sized to detain the new public streets and the new homes to be built on lots 1 through 4. Lots 5, 6, and 7 will provide lot-level detention and water quality systems at the time of building construction. Lots 5 and 6 will drain through the detention pond, and the pond will be sized to accommodate these anticipated flows. The future detention system on lot 7 will bypass the pond and flow directly to the public storm system in the park west of the development.

The fill required to bring Dubarko Road up to grade with Highway 26 will impede the flows of an existing drainage way that flows through the site. To remedy this, a new culvert will be installed under Dubarko Road. In the future, when lots 6 and 7 develop, a new bypass system will be designed to intercept the off-site flows draining to the project site and reroute them to the existing storm system to the west.

In addition to the on-site storm, improvements to the storm system in the ODOT right of way will occur as well. A new water quality facility will be constructed along Highway 26. This facility will conform to the requirements of the newest ODOT stormwater management manual at the time of design and construction. An existing 24" culvert which currently drains to the site will be intercepted, and the flows routed through an existing storm system in the ODOT right of way.

Upstream and downstream analyses will be performed as needed at the time of final engineering.

HYDROGRAPH PARAMETERS:

Rainfall

The rainfall distribution numbers below were taken from the City of Sandy Stormwater Website: <http://www.ci.sandy.or.us/Stormwater/>

- 2 year, 24 hr. rainfall = 3.5"
- 5 year, 24 hr. rainfall = 4.5"
- 10 year, 24 hr. rainfall = 4.8"
- 25 year, 24 hr. rainfall = 5.5"

Soils

The soil data for this site is from *Soil Survey of Clackamas County, Oregon* published by the United States Department of Agriculture (USDA). The post-development soil is assumed to be the same as pre-development.

- Soil Type: 15B, Cazadero silty clay loam. Hydrologic Group "C"
- 15C, Cazadero silty clay loam. Hydrologic Group "C"
- 24B, Cottrell silty clay loam. Hydrologic Group "C"

(See Appendix B for Runoff Curve Numbers)

Areas and Curve Numbers

Drainage basin areas were determined using a topographic map drafted in AutoCAD. See the Pre-Developed Area and Developed Area in Appendix A.

The impervious area for these post-developed basins includes the proposed roofs from lots 1 through 4, streets, sidewalks, driveways, and curbs. See the following tables for a specific breakdown of these areas.

Pre-Development		
Areas	CN	Land Use Description
Pervious (10.88 acres)*	83	Meadow & Young Second Growth Forest Land
Impervious (0.00 acres)	98	N/A
Post-Development		
Areas	CN	Land Use Description
Pervious (8.77 acres)**	83	Lawns "Good Condition", Meadow & Young Second Growth Forest
Impervious (2.11 acres)***	98	Buildings, AC, Sidewalks, etc.

*Pre-Developed Pervious CN: Weighted CN

Meadow or Pasture 5.19 AC: CN = 85

Wood or Forest Land "Young Second Growth" 5.68 AC: CN = 81

$[(5.19AC \times 85) + (5.68AC \times 81)] / (5.19+5.68) = 82.91 = \mathbf{83.0}$

Pre-Developed Impervious CN: See Runoff Curve Numbers Appendix B

**Post-Developed Pervious CN: Weighted CN

Meadow or Pasture 2.75 AC: CN = 85

Wood or Forest Land "Young Second Growth" 5.16 AC: CN = 81

Lawns "Good Condition" 0.85 AC: CN = 86

$[(2.75AC \times 85) + (5.16AC \times 81) + (0.85AC \times 86)] / (2.75+5.16+0.85) = 82.74 = \mathbf{83.0}$

***Refer to Water Quality Design Section for detailed area breakdown.

Post-Developed Impervious CN: See Runoff Curve Numbers Appendix B

Time of Concentration

The times of concentrations (T_c), were assumed as follows.

Pre-development T_c= 30.0 minutes

Post-development T_c= 5.0 minutes

Hydrograph Modeling Results

Hydrographs for the site were determined using a spreadsheet based on the King County, Washington Hydrograph Program, version 4.21B, which uses the Santa Barbara Urban Hydrograph (SBUH) method.

DETENTION SIZING RESULTS:

The Post-Development flows were routed through a proposed 4-foot deep detention pond. The 4-foot deep detention pond has been designed so that the Post-Developed release rates for the entire site do not exceed the Pre-Developed rates for the 2-year, 5-year, 10-year, and 25-year storm events per the City of Sandy public Works Design Standards. See the Detention System Summary in Appendix B.

Hydrology Table			
Recurrence Interval (years)	Pre-developed Flows (cfs)	Developed Flows (cfs)	Proposed Release Rates (cfs)
2	3.42	6.14	3.23
5	5.30	8.99	4.77
10	5.88	9.87	5.71
25	7.26	11.94	7.07

The required storage volume is 12,323-cubic feet. This can be contained in a 4-foot deep pond with a bottom area of 2,443 square feet.

Flow Control:

The flow control orifices were designed to release the Post-development Peak-Q's at or below the Pre-developed Peak-Q's.
(See the Detention System Summary - Appendix B)

Orifice Table		
Orifice	Dia. (inches)	Height (feet)
Bottom	7.68	-2.50
Top	10.03	2.80

WATER QUALITY DESIGN:

CDS Storm Water Treatment Device

A CDS manhole by Contech Stormwater Solutions was designed for water quality for the site - see detail in Appendix B. The impervious area for the site includes AC pavement, sidewalks, and roofs. The impervious area is 2.11-acres.

Proposed asphalt, walks, etc.:	1.88 acres
Roof, Patio, Driveway*:	0.23 acres
Total Impervious Area:	2.11 acres

*40'x50' Building footprint:	2000SF
20'x20' Driveway:	400SF
10'x10' Patio:	100SF
Total:	2,500SF X 4 lots = 10,000SF

The flow (Q) from this runoff was calculated using the rational method ($Q = CIA$)

Where $Q = \text{flow (cfs)}$

$C = \text{runoff coefficient} = 0.90 \text{ pavement and Roofs}$

$I = \text{Intensity} = 0.2 \text{ inches per hour (Water Quality Design Storm)}$

$A = \text{Impervious Area} = 2.11 \text{ Acres}$

$$Q = 0.90 \times 0.2 \times 2.11$$

$$Q = 0.38 \text{ cfs}$$

The Contech Storm Water Treatment Device Model: CDS2015-4-C has a treatment capacity of 0.7 cfs which exceeds the required 0.38 cfs.

A Storm Water Treatment Device CDS Model CDS2015-4-C can be used to adequately treat the water for the site

CONCLUSIONS:

- The conveyance system for the proposed Bull Run Terrace Subdivision site has been sized to handle the peak 25-year, 24-hour storm.
- On-site detention has been designed to maintain existing downstream storm water runoff characteristics in accordance with the City of Sandy requirements.
- A CDS Storm Water Treatment Device will be used for water quality.

(This page intentionally left blank)

Appendix A

- Vicinity Map
- Site Layout
- Pre-Developed Areas
- Developed Areas

(This page intentionally left blank)

VICINITY MAP

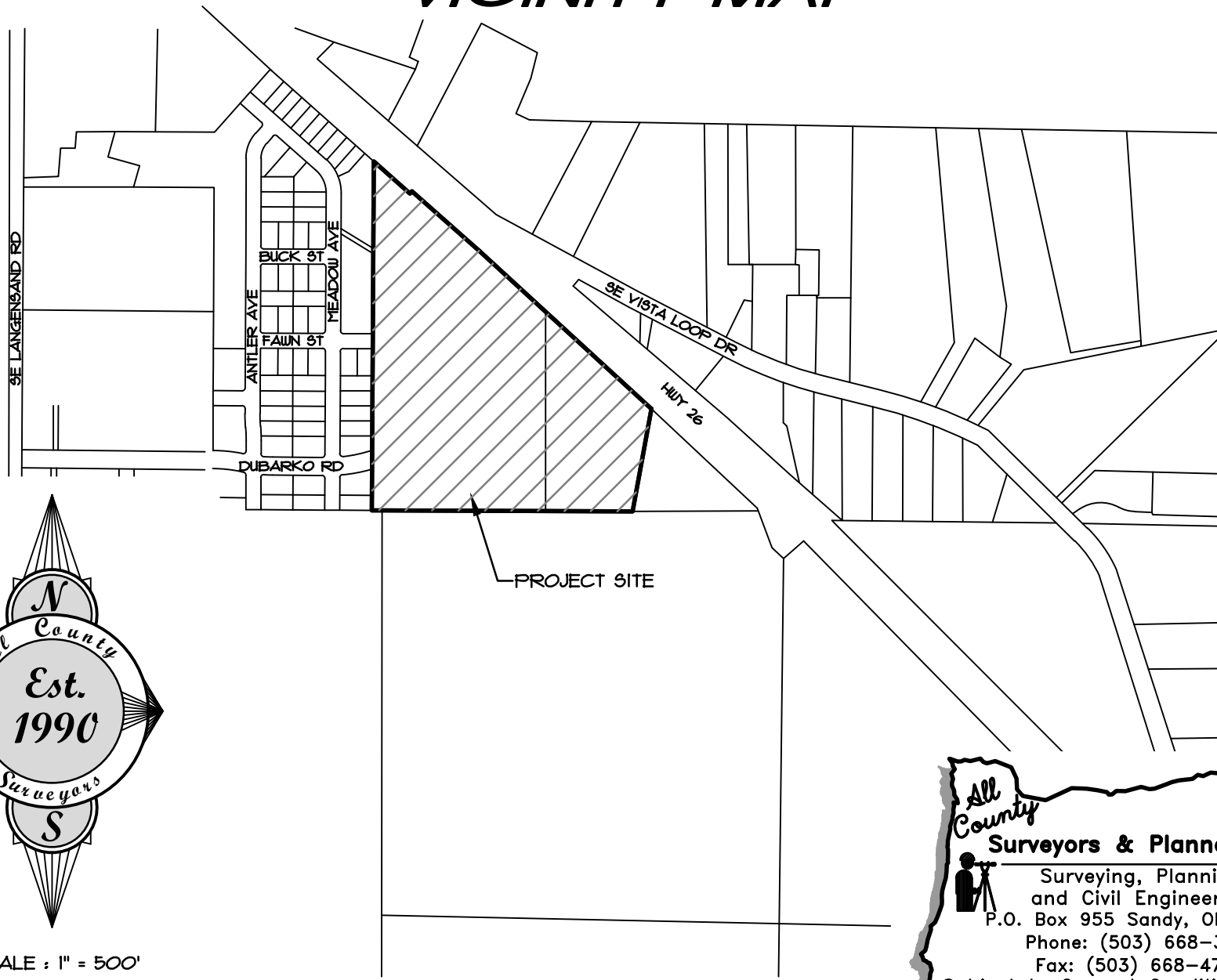

SCALE : 1" = 500'



All County Surveyors & Planners, Inc.
Surveying, Planning and Civil Engineering
P.O. Box 955 Sandy, OR 97055
Phone: (503) 668-3151
Fax: (503) 668-4730
Subject to General Conditions 2006 ©

SITE LAYOUT

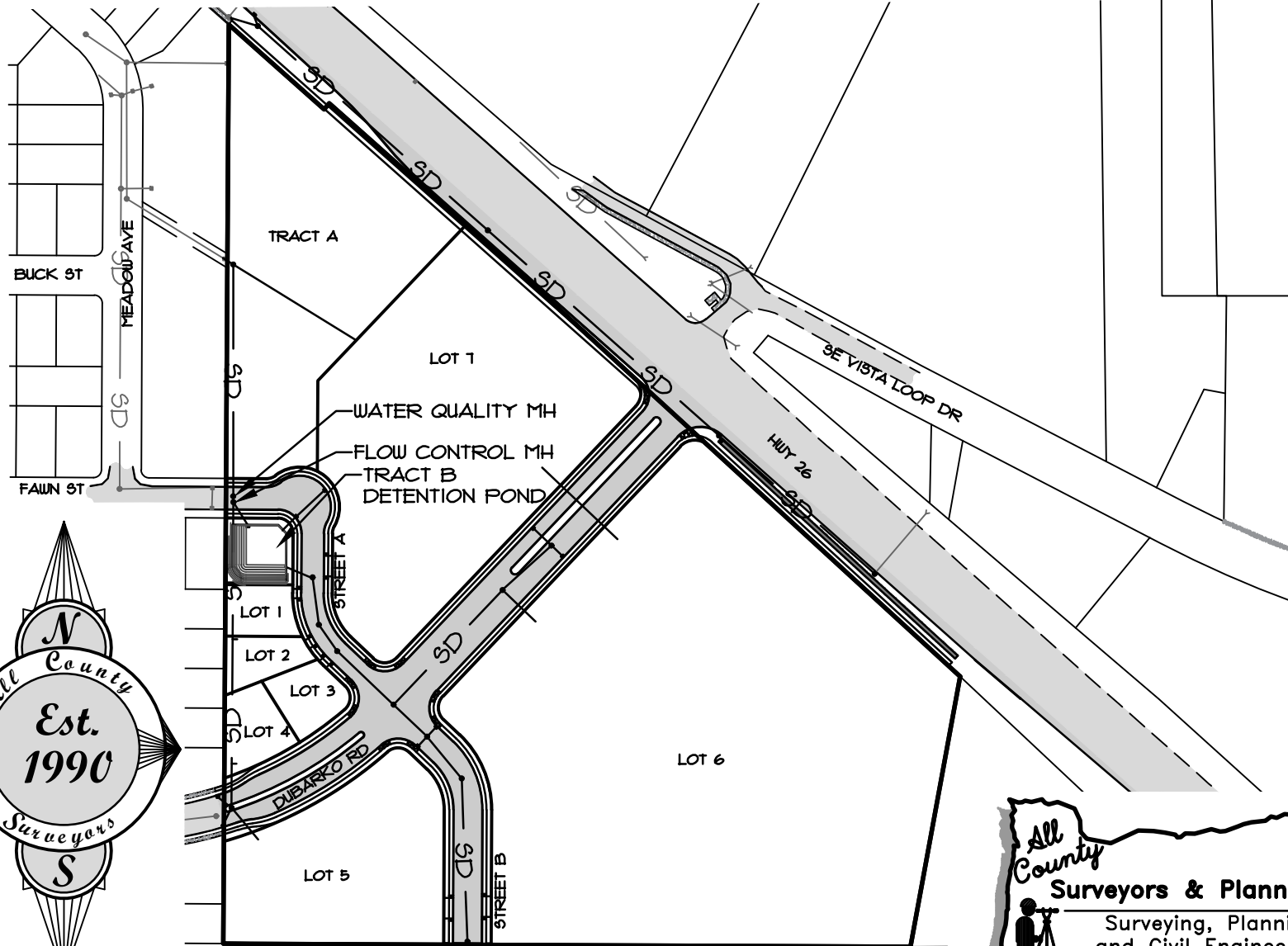

SCALE : 1" = 200'



All County
Surveyors & Planners, Inc.
 Surveying, Planning
 and Civil Engineering
 P.O. Box 955 Sandy, OR 97055
 Phone: (503) 668-3151
 Fax: (503) 668-4730
 Subject to General Conditions 2006 ©

PRE-DEVELOPED AREAS

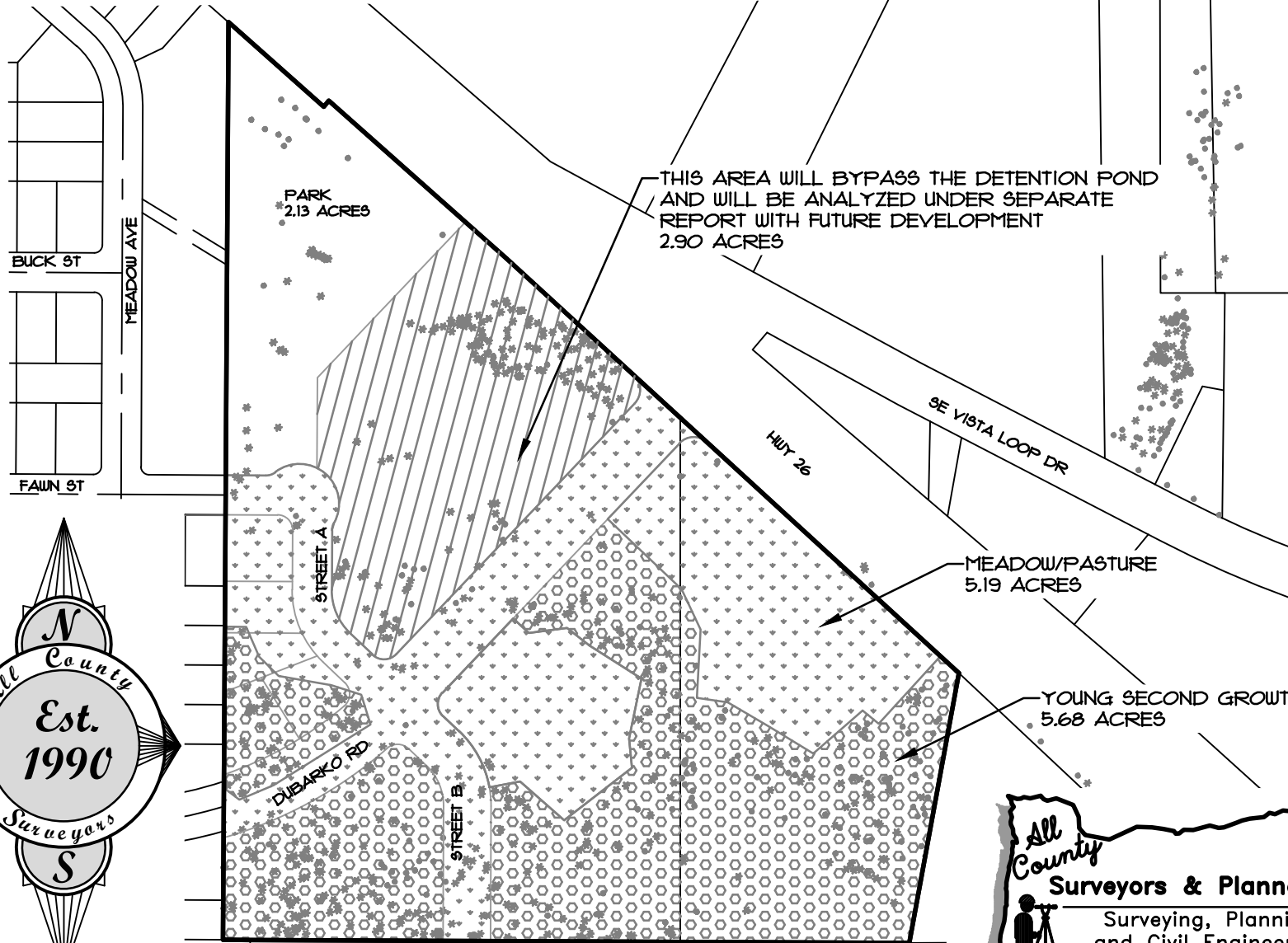

SCALE : 1" = 200'



All County
Surveyors & Planners, Inc.
 Surveying, Planning
 and Civil Engineering
 P.O. Box 955 Sandy, OR 97055
 Phone: (503) 668-3151
 Fax: (503) 668-4730
 Subject to General Conditions 2006 ©

DEVELOPED AREAS

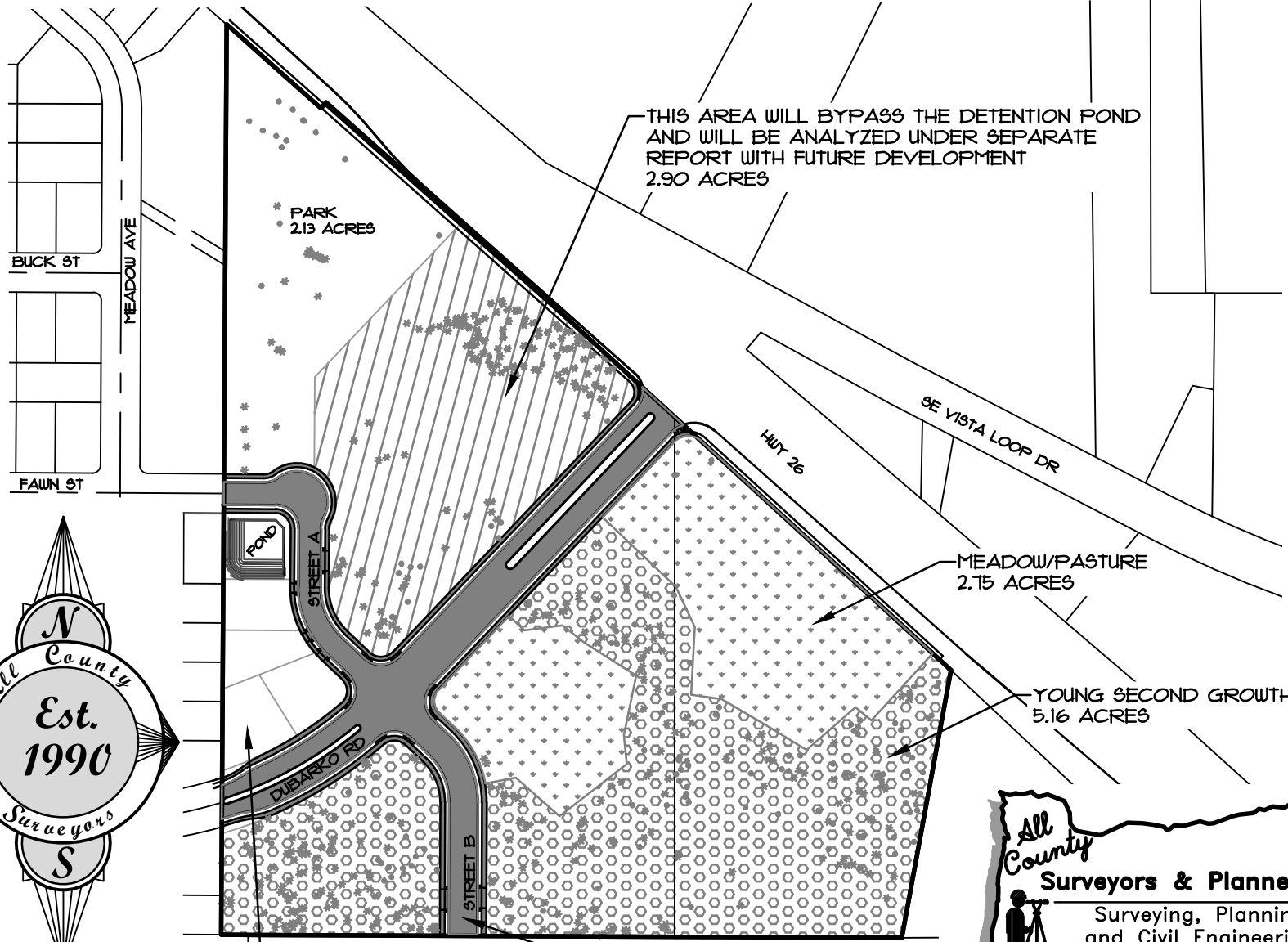

THIS AREA WILL BYPASS THE DETENTION POND AND WILL BE ANALYZED UNDER SEPARATE REPORT WITH FUTURE DEVELOPMENT
2.90 ACRES

* PARK
2.13 ACRES

MEADOW/PASTURE
2.75 ACRES

YOUNG SECOND GROWTH
5.16 ACRES

LAWNS IN GOOD CONDITION
0.85 ACRES**

IMPERVIOUS: AC, SIDEWALKS,
CURBS, ROOFS**
2.11 ACRES



SCALE : 1" = 200'



** REFER TO BODY OF STORM REPORT
FOR BREAKDOWN OF LOT-LEVEL
IMPERVIOUS AREA

All County Surveyors & Planners, Inc.
 Surveying, Planning and Civil Engineering
 P.O. Box 955 Sandy, OR 97055
 Phone: (503) 668-3151
 Fax: (503) 668-4730
 Subject to General Conditions 2006 ©

Appendix B

- Standard Formulas
- Coefficients
- SCS Runoff Curve Numbers (CN)
- Hydrograph Analysis Summary
- Detention System Summary
- Stage Storage Summary
- Rectangular, Sharp Crested Weir Calculations
- Contech CDS2015-4-C Detail

(This page intentionally left blank)

Standard formulas used for the Time of Concentration Calculations

Overland Flow (max 300' total)

$$\frac{(0.42)[(N_s)(L)]^{0.8}}{(P_2)^{0.5}(S_0)^{0.4}}$$

Tc	= time of concentration for less than 300' of travel (minutes)
Ns	= sheet flow Manning's effective roughness coefficient
L	= flow length (ft)
P2	= 2-year, 24 hour rainfall (in)
So	= slope of hydraulic grade line (land slope, ft/ft)

Shallow Concentrated Flow (after initial 300')

$$T = \frac{L}{(60)(k\sqrt{S_0})}$$

T	= travel time for sheet flow (min)
L	= flow length (ft)
So	= slope of hydraulic grade line (land slope, ft/ft)
k	= time of concentration velocity factor (ft/s)

Flow in Swales

Q = (1.486/n) x A x R^{2/3} x S^{1/2} (Manning's Equation)

Tc	= time of concentration for gutter flow (minutes)
A	= area of flow (sf)
R	= hydraulic radius (ft)
Ls	= side slope
Q	= quantity of flow (ft ³ /sec)
V	= average velocity of flow (ft/sec)
L	= length of flow
Ve	= vertical length of side slope
Ho	= horizontal length of side slope
Bw	= base width (in)
D	= depth (in)
S	= slope (ft/ft)
n	= Manning's n

Flow in gutters

$$V = \frac{1.12}{n} (S)^{0.5} (S_x)^{.67} (T)^{0.67}$$

Tc	= time of concentration for gutter flow (minutes)
V	= average velocity of flow (ft/sec)
Q	= quantity of flow (ft ³ /sec)
S	= street longitudinal slope (ft/ft)
Sx	= street cross slope (ft/ft)
T	= total width of flow in the gutter (ft)
n	= sheet flow Manning's (pavement = 0.018)
L	= Length of flow (ft)

Flow in pipes

Mannings Equation

Tc	= time of concentration in pipe (minutes)
V	= calculated velocity pipe full (ft/sec)
Q	= quantity of flow (ft ³ /sec)
n	= Manning's n
D	= pipe Diameter (in)
S	= slope (ft/ft)
L	= length of pipe

COEFFICIENTS

$N_s =$ = Manning's coefficient (sheet flow)

n values are for sheet flow only

Design Value

- 0.011 Concrete or asphalt
- 0.010 Bare soil
- 0.020 Graveled surface
- 0.020 Bare clay - loam (eroded)
- 0.150 Grass (short prairie)
- 0.240 Grass (dense lawn)
- 0.410 Grass (bermuda)
- 0.400 Woods (light underbrush)
- 0.800 Woods (dense underbrush)

$k =$ = time of concentration velocity factor (ft/s)

Design Value

- 3 Forest with heavy ground cover and meadows (n=0.10)
- 5 Brushy ground with some trees (n=0.060)
- 8 Fallow or cultivation (n=0.040)
- 9 High grass (n=0.035)
- 11 Short grass, pasture or lawns (n=0.030)
- 13 Nearly bare ground (n=0.025)
- 27 Paved and gravel areas (n=0.012)

$n =$ = Manning's coefficient (channel)

Design Value

CONSTRUCTED CHANNELS

A. Earth, straight and uniform

- 0.018 Earth (straight and uniform)
- 0.025 Gravel (straight and uniform)
- 0.027 Grass (with weeds)

B. Earth, winding and sluggish

- 0.025 Earth (no vegetation)
- 0.030 Grass (some weeds)
- 0.035 Dense weeds (deep channel)
- 0.030 Earth (rubble bottom and sides)
- 0.035 Stony bottom and weedy banks
- 0.040 Cobble bottom with clean sides

C. Rock lined

- 0.035 Smooth and uniform
- 0.040 Jagged and irregular

D. Channels not maintained (weeds and brush uncut)

- 0.050 Dense weeds (high as flow depth)
- 0.050 Clean bottom (brush on sides)
- 0.100 Dense brush (high stage)
- 0.200 Water quality swales (mowed regulary)

NATURAL STREAMS

- 0.029 Clean (straight no pools)
- 0.035 Clean (straight no pools with weeds and stones)
- 0.039 Clean (winding pools)
- 0.042 Clean (winding pools weeds and stones)
- 0.052 Clean (winding pools weeds and large stones)
- 0.065 Weedy (sluggish with deep pools)
- 0.112 Very weedy (sluggish with deep pools)

SCS RUNOFF CURVE NUMBERS (CN)

For Selected Land Uses

LAND USE DESCRIPTION		RUNOFF CURVE NUMBERS (CN) BY HYDROLOGIC SOIL GROUP			
		A	B	C	D
Cultivated land (1):	winter condition	86	91	94	95
Mountain open areas:	low growing brush and grasslands	74	82	89	92
Meadow or pasture:		65	78	85	89
Wood or forest land:	undisturbed or older second growth	42	64	76	81
Wood or forest land:	young second growth or brush	55	72	81	86
Orchard:	with cover crop	81	88	92	94
Open spaces, lawns, parks, golf courses, cemeteries, landscaping					
Good condition:	grass cover on 75% or more of the area	68	80	86	90
Fair condition:	grass cover on 50% to 75% of the area	77	85	90	92
Gravel roads and parking lots		76	85	89	91
Dirt Roads and parking lots		72	82	87	89
Impervious surfaces:	pavement, roof, etc.	98	98	98	98
Open water bodies:	lakes, wetlands, ponds, etc.	100	100	100	100
Single Family Residential (2)					
Dwelling Unit/Gross Acre (DU/GA)	% Impervious (3)	Select separate curve numbers for the pervious and impervious portion of the site or basin.			
1.0	15				
2.0	25				
3.0	34				
4.0	42				
5.0	48				
6.0	52				
7.0	56				
Planned unit developments, condominiums, apartments, commercial businesses and industrial areas.		Use actual impervious area.			
<p>(1) Detailed information relating to specific agricultural land uses is available in the National Engineering Engineering Handbook, Section 4, Hydrology, chapter 9, August 1972.</p> <p>(2) Assume site drains to storm system.</p> <p>(3) For this land use, the remaining pervious areas are assumed to be lawn in good condition.</p>					

Project Name: Bull Run Terrace

Hydrograph Analysis Summary

Job # 019-035
Date: 11/20/2019

Rainfall (year)	Rainfall (inches)
2	3.50
5	4.50
10	4.80
25	5.50
100	0.00

Pre-Developed	
Pervious	
Area =	10.88 acres
CN =	83 na
Impervious	
Area =	0 acres
CN =	98 na
Tc =	30 min
Total A =	10.88 acres

Developed	
Pervious	
Area =	8.77 acres
CN =	83 na
Impervious	
Area =	2.11 acres
CN =	98 na
Tc =	5 min
Total A =	10.88 acres

Note: The hydrographs shown are based on the S.C.S. Type - 1A, 24 hour storm using the SBUH method based on the King County Model.

Pre-Developed Hydrographs						
Year	=====>	2	5	10	25	100
Qpeak	cfs =>	3.42	5.30	5.88	7.26	0.00
Volume	cf =>	73,183	107,346	117,913	142,981	-
Tpeak	min =>	480	480	480	480	10
Tpeak	hr =>	8.00	8.00	8.00	8.00	0.17
Hydrograph Name=>		2	5	10	25	100
Time (min)	Time (hr)	Hyd (cfs)	Hyd (cfs)	Hyd (cfs)	Hyd (cfs)	Hyd (cfs)
0	0.00	0.00	0.00	0.00	0.00	0.00
10	0.17	0.00	0.00	0.00	0.00	0.00
20	0.33	0.00	0.00	0.00	0.00	0.00
30	0.50	0.00	0.00	0.00	0.00	0.00
40	0.67	0.00	0.00	0.00	0.00	0.00
50	0.83	0.00	0.00	0.00	0.00	0.00
60	1.00	0.00	0.00	0.00	0.00	0.00
70	1.17	0.00	0.00	0.00	0.00	0.00
80	1.33	0.00	0.00	0.00	0.00	0.00
90	1.50	0.00	0.00	0.00	0.00	0.00
100	1.67	0.00	0.00	0.00	0.00	0.00
110	1.83	0.00	0.00	0.00	0.00	0.00
120	2.00	0.00	0.00	0.00	0.00	0.00
130	2.17	0.00	0.00	0.00	0.00	0.00
140	2.33	0.00	0.00	0.00	0.00	0.00
150	2.50	0.00	0.00	0.00	0.00	0.00
160	2.67	0.00	0.00	0.00	0.00	0.00
170	2.83	0.00	0.00	0.00	0.00	0.00
180	3.00	0.00	0.00	0.00	0.01	0.00
190	3.17	0.00	0.00	0.00	0.03	0.00
200	3.33	0.00	0.00	0.01	0.06	0.00
210	3.50	0.00	0.01	0.03	0.11	0.00
220	3.67	0.00	0.03	0.05	0.15	0.00
230	3.83	0.00	0.05	0.09	0.21	0.00
240	4.00	0.00	0.09	0.14	0.28	0.00
250	4.17	0.01	0.13	0.19	0.35	0.00
260	4.33	0.02	0.18	0.24	0.42	0.00
270	4.50	0.04	0.23	0.30	0.48	0.00
280	4.67	0.06	0.27	0.35	0.55	0.00
290	4.83	0.10	0.33	0.42	0.63	0.00
300	5.00	0.13	0.40	0.49	0.73	0.00
310	5.17	0.17	0.46	0.56	0.82	0.00
320	5.33	0.21	0.53	0.63	0.90	0.00
330	5.50	0.25	0.59	0.70	0.98	0.00
340	5.67	0.29	0.64	0.76	1.05	0.00
350	5.83	0.34	0.72	0.84	1.15	0.00
360	6.00	0.40	0.80	0.94	1.27	0.00
370	6.17	0.45	0.88	1.03	1.37	0.00
380	6.33	0.50	0.96	1.10	1.47	0.00
390	6.50	0.55	1.02	1.18	1.55	0.00
400	6.67	0.60	1.09	1.24	1.63	0.00
410	6.83	0.69	1.22	1.39	1.81	0.00
420	7.00	0.81	1.41	1.60	2.07	0.00
430	7.17	0.92	1.57	1.78	2.28	0.00
440	7.33	1.08	1.82	2.05	2.61	0.00
450	7.50	1.29	2.13	2.40	3.04	0.00
460	7.67	1.73	2.80	3.13	3.93	0.00
470	7.83	2.73	4.30	4.79	5.96	0.00
480	8.00	3.42	5.30	5.88	7.26	0.00
490	8.17	3.31	5.08	5.62	6.92	0.00
500	8.33	2.98	4.55	5.03	6.18	0.00
510	8.50	2.68	4.05	4.48	5.48	0.00
520	8.67	2.46	3.71	4.09	4.99	0.00

Developed Hydrographs						
Year	=====>	2	5	10	25	100
Qpeak	cfs =>	6.14	8.99	9.87	11.94	0.00
Volume	cf =>	84,150	119,380	130,207	155,802	-
Tpeak	min =>	470	470	470	470	10
Tpeak	hr =>	7.83	7.83	7.83	7.83	0.17
Hydrograph Name=>		2	5	10	25	100
Time (min)	Time (hr)	Hyd (cfs)	Hyd (cfs)	Hyd (cfs)	Hyd (cfs)	Hyd (cfs)
0	0.00	0.00	0.00	0.00	0.00	0.00
10	0.17	0.00	0.00	0.00	0.00	0.00
20	0.33	0.00	0.00	0.00	0.00	0.00
30	0.50	0.00	0.01	0.01	0.02	0.00
40	0.67	0.01	0.03	0.03	0.06	0.00
50	0.83	0.02	0.06	0.07	0.09	0.00
60	1.00	0.04	0.08	0.09	0.12	0.00
70	1.17	0.06	0.10	0.11	0.15	0.00
80	1.33	0.07	0.11	0.13	0.16	0.00
90	1.50	0.08	0.13	0.14	0.18	0.00
100	1.67	0.09	0.14	0.15	0.19	0.00
110	1.83	0.11	0.17	0.19	0.23	0.00
120	2.00	0.13	0.20	0.22	0.26	0.00
130	2.17	0.14	0.21	0.23	0.27	0.00
140	2.33	0.15	0.22	0.24	0.28	0.00
150	2.50	0.16	0.22	0.24	0.29	0.00
160	2.67	0.16	0.23	0.25	0.30	0.00
170	2.83	0.18	0.26	0.28	0.33	0.00
180	3.00	0.21	0.29	0.31	0.39	0.00
190	3.17	0.21	0.29	0.32	0.44	0.00
200	3.33	0.22	0.30	0.34	0.50	0.00
210	3.50	0.22	0.32	0.39	0.55	0.00
220	3.67	0.23	0.36	0.43	0.60	0.00
230	3.83	0.25	0.44	0.51	0.71	0.00
240	4.00	0.27	0.51	0.60	0.82	0.00
250	4.17	0.29	0.56	0.65	0.88	0.00
260	4.33	0.32	0.61	0.70	0.94	0.00
270	4.50	0.35	0.65	0.75	0.99	0.00
280	4.67	0.38	0.69	0.79	1.04	0.00
290	4.83	0.45	0.79	0.91	1.19	0.00
300	5.00	0.52	0.90	1.03	1.34	0.00
310	5.17	0.56	0.95	1.08	1.39	0.00
320	5.33	0.59	1.00	1.13	1.45	0.00
330	5.50	0.63	1.04	1.18	1.50	0.00
340	5.67	0.66	1.08	1.22	1.55	0.00
350	5.83	0.75	1.22	1.37	1.73	0.00
360	6.00	0.84	1.35	1.52	1.91	0.00
370	6.17	0.88	1.40	1.57	1.97	0.00
380	6.33	0.91	1.45	1.62	2.02	0.00
390	6.50	0.95	1.49	1.66	2.07	0.00
400	6.67	0.98	1.53	1.71	2.12	0.00
410	6.83	1.22	1.89	2.11	2.61	0.00
420	7.00	1.48	2.27	2.52	3.12	0.00
430	7.17	1.54	2.34	2.59	3.19	0.00
440	7.33	1.88	2.84	3.14	3.86	0.00
450	7.50	2.24	3.37	3.71	4.54	0.00
460	7.67	3.42	5.07	5.58	6.79	0.00
470	7.83	6.14	8.99	9.87	11.94	0.00
480	8.00	5.91	8.57	9.39	11.31	0.00
490	8.17	3.44	4.93	5.39	6.46	0.00
500	8.33	2.45	3.50	3.82	4.57	0.00
510	8.50	2.12	3.02	3.30	3.94	0.00
520	8.67	2.15	3.05	3.33	3.97	0.00

Pre-Developed Hydrographs							Developed Hydrographs				
Year	=====>	2	5	10	25	100	2	5	10	25	100
Qpeak	cfs =>	3.42	5.30	5.88	7.26	0.00	6.14	8.99	9.87	11.94	0.00
Volume	cf =>	73,183	107,346	117,913	142,981	-	84,150	119,380	130,207	155,802	-
Tpeak	min =>	480	480	480	480	10	470	470	470	470	10
Tpeak	hr =>	8.00	8.00	8.00	8.00	0.17	7.83	7.83	7.83	7.83	0.17
Hydrograph Name=>		2	5	10	25	100	2	5	10	25	100
Time	Time	Hyd	Hyd	Hyd	Hyd	Hyd	Hyd	Hyd	Hyd	Hyd	Hyd
(min)	(hr)	(cfs)	(cfs)	(cfs)	(cfs)	(cfs)	(cfs)	(cfs)	(cfs)	(cfs)	(cfs)
530	8.83	2.22	3.33	3.66	4.46	0.00	1.80	2.55	2.78	3.31	0.00
540	9.00	1.96	2.92	3.21	3.91	0.00	1.44	2.04	2.22	2.64	0.00
550	9.17	1.78	2.63	2.90	3.51	0.00	1.45	2.05	2.23	2.65	0.00
560	9.33	1.65	2.43	2.67	3.23	0.00	1.46	2.06	2.24	2.66	0.00
570	9.50	1.56	2.29	2.52	3.04	0.00	1.47	2.07	2.25	2.67	0.00
580	9.67	1.50	2.20	2.41	2.90	0.00	1.48	2.08	2.26	2.68	0.00
590	9.83	1.46	2.13	2.34	2.81	0.00	1.49	2.09	2.27	2.70	0.00
600	10.00	1.44	2.09	2.29	2.75	0.00	1.50	2.10	2.28	2.71	0.00
610	10.17	1.42	2.06	2.25	2.71	0.00	1.51	2.11	2.29	2.71	0.00
620	10.33	1.42	2.04	2.24	2.68	0.00	1.52	2.12	2.30	2.72	0.00
630	10.50	1.41	2.04	2.22	2.67	0.00	1.53	2.13	2.31	2.73	0.00
640	10.67	1.42	2.03	2.22	2.66	0.00	1.53	2.14	2.32	2.74	0.00
650	10.83	1.38	1.98	2.16	2.59	0.00	1.40	1.95	2.11	2.50	0.00
660	11.00	1.32	1.89	2.07	2.47	0.00	1.27	1.76	1.91	2.26	0.00
670	11.17	1.28	1.83	2.00	2.39	0.00	1.27	1.77	1.91	2.26	0.00
680	11.33	1.26	1.79	1.95	2.33	0.00	1.28	1.77	1.92	2.27	0.00
690	11.50	1.24	1.76	1.92	2.29	0.00	1.28	1.78	1.92	2.27	0.00
700	11.67	1.23	1.74	1.90	2.26	0.00	1.29	1.78	1.93	2.28	0.00
710	11.83	1.22	1.73	1.89	2.25	0.00	1.29	1.79	1.93	2.28	0.00
720	12.00	1.22	1.73	1.88	2.24	0.00	1.30	1.79	1.94	2.29	0.00
730	12.17	1.22	1.72	1.88	2.23	0.00	1.30	1.80	1.94	2.29	0.00
740	12.33	1.22	1.72	1.88	2.23	0.00	1.31	1.80	1.95	2.30	0.00
750	12.50	1.22	1.72	1.88	2.23	0.00	1.31	1.80	1.95	2.30	0.00
760	12.67	1.23	1.73	1.88	2.23	0.00	1.31	1.81	1.96	2.31	0.00
770	12.83	1.19	1.68	1.83	2.17	0.00	1.18	1.62	1.76	2.07	0.00
780	13.00	1.13	1.59	1.73	2.06	0.00	1.05	1.44	1.56	1.83	0.00
790	13.17	1.09	1.53	1.67	1.98	0.00	1.05	1.44	1.56	1.83	0.00
800	13.33	1.06	1.49	1.62	1.92	0.00	1.05	1.44	1.56	1.84	0.00
810	13.50	1.04	1.46	1.59	1.88	0.00	1.05	1.45	1.56	1.84	0.00
820	13.67	1.03	1.44	1.57	1.86	0.00	1.06	1.45	1.57	1.84	0.00
830	13.83	1.02	1.43	1.55	1.84	0.00	1.06	1.45	1.57	1.84	0.00
840	14.00	1.02	1.42	1.54	1.83	0.00	1.06	1.45	1.57	1.85	0.00
850	14.17	1.01	1.42	1.54	1.82	0.00	1.06	1.46	1.57	1.85	0.00
860	14.33	1.01	1.41	1.53	1.81	0.00	1.07	1.46	1.58	1.85	0.00
870	14.50	1.01	1.41	1.53	1.81	0.00	1.07	1.46	1.58	1.85	0.00
880	14.67	1.01	1.41	1.53	1.81	0.00	1.07	1.46	1.58	1.86	0.00
890	14.83	1.00	1.39	1.50	1.78	0.00	1.01	1.38	1.49	1.74	0.00
900	15.00	0.97	1.35	1.46	1.72	0.00	0.94	1.29	1.39	1.63	0.00
910	15.17	0.95	1.32	1.43	1.69	0.00	0.94	1.29	1.39	1.63	0.00
920	15.33	0.93	1.30	1.41	1.66	0.00	0.95	1.29	1.39	1.63	0.00
930	15.50	0.92	1.28	1.39	1.64	0.00	0.95	1.29	1.40	1.64	0.00
940	15.67	0.92	1.27	1.38	1.63	0.00	0.95	1.29	1.40	1.64	0.00
950	15.83	0.91	1.27	1.37	1.62	0.00	0.95	1.30	1.40	1.64	0.00
960	16.00	0.91	1.26	1.37	1.62	0.00	0.95	1.30	1.40	1.64	0.00
970	16.17	0.91	1.26	1.37	1.61	0.00	0.95	1.30	1.40	1.64	0.00
980	16.33	0.91	1.26	1.37	1.61	0.00	0.96	1.30	1.40	1.64	0.00
990	16.50	0.91	1.26	1.37	1.61	0.00	0.96	1.30	1.41	1.65	0.00
1000	16.67	0.91	1.26	1.37	1.61	0.00	0.96	1.30	1.41	1.65	0.00
1010	16.83	0.89	1.23	1.33	1.56	0.00	0.86	1.17	1.27	1.48	0.00
1020	17.00	0.84	1.16	1.26	1.49	0.00	0.77	1.04	1.13	1.32	0.00
1030	17.17	0.81	1.12	1.21	1.43	0.00	0.77	1.05	1.13	1.32	0.00
1040	17.33	0.79	1.09	1.18	1.39	0.00	0.77	1.05	1.13	1.32	0.00
1050	17.50	0.78	1.07	1.16	1.36	0.00	0.77	1.05	1.13	1.32	0.00
1060	17.67	0.76	1.05	1.14	1.34	0.00	0.77	1.05	1.13	1.32	0.00
1070	17.83	0.76	1.04	1.13	1.33	0.00	0.77	1.05	1.13	1.32	0.00
1080	18.00	0.75	1.04	1.12	1.32	0.00	0.77	1.05	1.13	1.33	0.00
1090	18.17	0.75	1.03	1.12	1.31	0.00	0.78	1.05	1.13	1.33	0.00
1100	18.33	0.75	1.03	1.11	1.31	0.00	0.78	1.05	1.13	1.33	0.00
1110	18.50	0.75	1.03	1.11	1.31	0.00	0.78	1.05	1.14	1.33	0.00
1120	18.67	0.75	1.03	1.11	1.30	0.00	0.78	1.05	1.14	1.33	0.00
1130	18.83	0.75	1.03	1.11	1.30	0.00	0.78	1.05	1.14	1.33	0.00
1140	19.00	0.75	1.03	1.11	1.30	0.00	0.78	1.06	1.14	1.33	0.00
1150	19.17	0.75	1.03	1.11	1.30	0.00	0.78	1.06	1.14	1.33	0.00
1160	19.33	0.75	1.03	1.11	1.30	0.00	0.78	1.06	1.14	1.33	0.00
1170	19.50	0.75	1.03	1.11	1.30	0.00	0.78	1.06	1.14	1.33	0.00
1180	19.67	0.75	1.03	1.11	1.30	0.00	0.78	1.06	1.14	1.33	0.00
1190	19.83	0.75	1.03	1.11	1.31	0.00	0.78	1.06	1.14	1.33	0.00
1200	20.00	0.75	1.03	1.11	1.31	0.00	0.78	1.06	1.14	1.33	0.00
1210	20.17	0.75	1.03	1.11	1.31	0.00	0.79	1.06	1.14	1.34	0.00
1220	20.33	0.75	1.03	1.11	1.31	0.00	0.79	1.06	1.14	1.34	0.00
1230	20.50	0.75	1.03	1.12	1.31	0.00	0.79	1.06	1.15	1.34	0.00

Pre-Developed Hydrographs							Developed Hydrographs					
Year	=====>	2	5	10	25	100	2	5	10	25	100	
Qpeak	cfs =>	3.42	5.30	5.88	7.26	0.00	6.14	8.99	9.87	11.94	0.00	
Volume	cf =>	73,183	107,346	117,913	142,981	-	84,150	119,380	130,207	155,802	-	
Tpeak	min =>	480	480	480	480	10	470	470	470	470	10	
Tpeak	hr =>	8.00	8.00	8.00	8.00	0.17	7.83	7.83	7.83	7.83	0.17	
Hydrograph Name=>		2	5	10	25	100	2	5	10	25	100	
Time	Time	Hyd	Hyd	Hyd	Hyd	Hyd	Hyd	Hyd	Hyd	Hyd	Hyd	
(min)	(hr)	(cfs)	(cfs)	(cfs)	(cfs)	(cfs)	(cfs)	(cfs)	(cfs)	(cfs)	(cfs)	
1240	20.67	0.75	1.03	1.12	1.31	0.00	0.79	1.06	1.15	1.34	0.00	
1250	20.83	0.76	1.03	1.12	1.31	0.00	0.79	1.06	1.15	1.34	0.00	
1260	21.00	0.76	1.03	1.12	1.31	0.00	0.79	1.07	1.15	1.34	0.00	
1270	21.17	0.76	1.04	1.12	1.31	0.00	0.79	1.07	1.15	1.34	0.00	
1280	21.33	0.76	1.04	1.12	1.31	0.00	0.79	1.07	1.15	1.34	0.00	
1290	21.50	0.76	1.04	1.12	1.31	0.00	0.79	1.07	1.15	1.34	0.00	
1300	21.67	0.76	1.04	1.12	1.31	0.00	0.79	1.07	1.15	1.34	0.00	
1310	21.83	0.76	1.04	1.12	1.32	0.00	0.79	1.07	1.15	1.34	0.00	
1320	22.00	0.76	1.04	1.12	1.32	0.00	0.79	1.07	1.15	1.34	0.00	
1330	22.17	0.76	1.04	1.12	1.32	0.00	0.79	1.07	1.15	1.34	0.00	
1340	22.33	0.76	1.04	1.12	1.32	0.00	0.80	1.07	1.15	1.34	0.00	
1350	22.50	0.76	1.04	1.13	1.32	0.00	0.80	1.07	1.15	1.35	0.00	
1360	22.67	0.77	1.04	1.13	1.32	0.00	0.80	1.07	1.15	1.35	0.00	
1370	22.83	0.77	1.04	1.13	1.32	0.00	0.80	1.07	1.16	1.35	0.00	
1380	23.00	0.77	1.05	1.13	1.32	0.00	0.80	1.07	1.16	1.35	0.00	
1390	23.17	0.77	1.05	1.13	1.32	0.00	0.80	1.07	1.16	1.35	0.00	
1400	23.33	0.77	1.05	1.13	1.32	0.00	0.80	1.07	1.16	1.35	0.00	
1410	23.50	0.77	1.05	1.13	1.32	0.00	0.80	1.08	1.16	1.35	0.00	
1420	23.67	0.77	1.05	1.13	1.32	0.00	0.80	1.08	1.16	1.35	0.00	
1430	23.83	0.77	1.05	1.13	1.33	0.00	0.80	1.08	1.16	1.35	0.00	
1440	24.00	0.77	1.05	1.13	1.33	0.00	0.80	1.08	1.16	1.35	0.00	
1450	24.17	0.66	0.90	0.97	1.14	0.00	0.40	0.54	0.58	0.68	0.00	
1460	24.33	0.47	0.64	0.69	0.81	0.00	0.00	0.00	0.00	0.00	0.00	
1470	24.50	0.34	0.46	0.50	0.58	0.00	0.00	0.00	0.00	0.00	0.00	
1480	24.67	0.24	0.33	0.35	0.41	0.00	0.00	0.00	0.00	0.00	0.00	
1490	24.67	0.17	0.23	0.25	0.30	0.00	0.00	0.00	0.00	0.00	0.00	
1500	24.67	0.12	0.17	0.18	0.21	0.00	0.00	0.00	0.00	0.00	0.00	

Pre-Developed Hydrographs						
Year	=====>	2	5	10	25	100
Qpeak	cfs =>	3.42	5.30	5.88	7.26	0.00
Volume	cf =>	73,183	107,346	117,913	142,981	-
Tpeak	min =>	480	480	480	480	10
Tpeak	hr =>	8.00	8.00	8.00	8.00	0.17
Hydrograph Name=>		2	5	10	25	100
Time	Time	Hyd	Hyd	Hyd	Hyd	Hyd
(min)	(hr)	(cfs)	(cfs)	(cfs)	(cfs)	(cfs)

Developed Hydrographs					
	2	5	10	25	100
Qpeak	6.14	8.99	9.87	11.94	0.00
Volume	84,150	119,380	130,207	155,802	-
Tpeak	470	470	470	470	10
Tpeak	7.83	7.83	7.83	7.83	0.17
Hydrograph Name=>	2	5	10	25	100
Time	Hyd	Hyd	Hyd	Hyd	Hyd
(cfs)	(cfs)	(cfs)	(cfs)	(cfs)	(cfs)

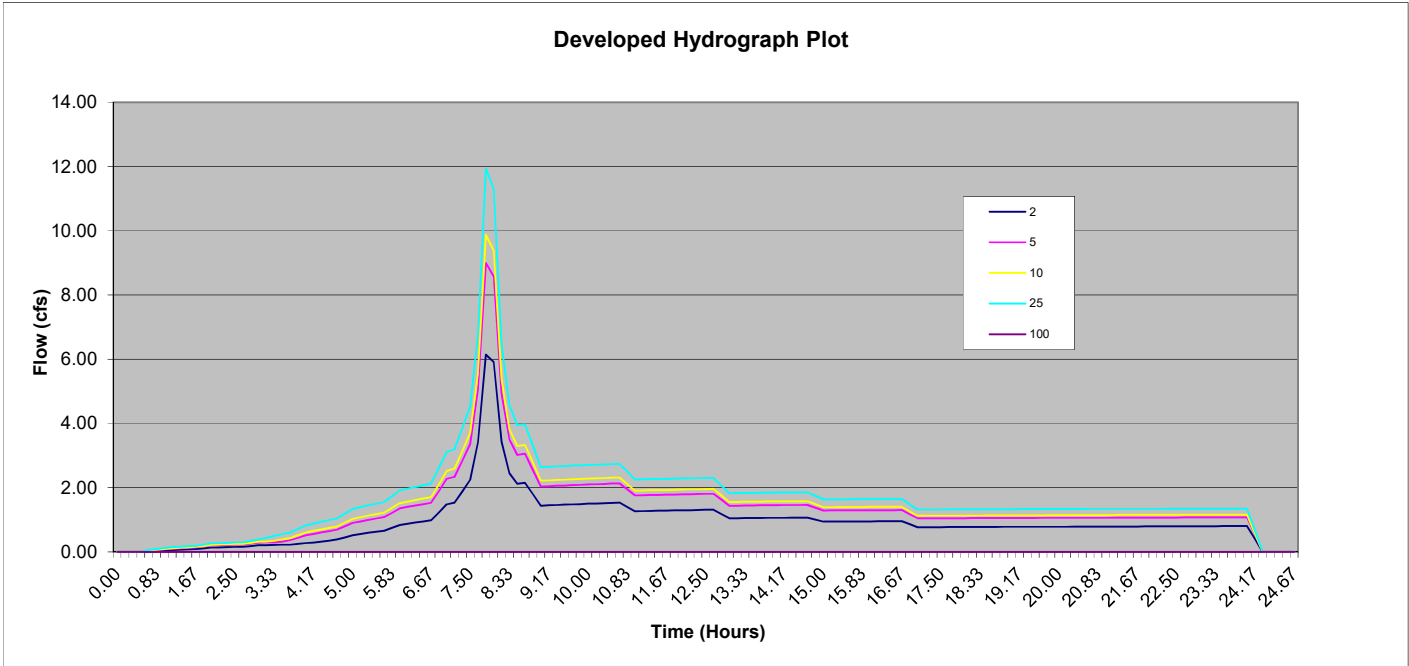
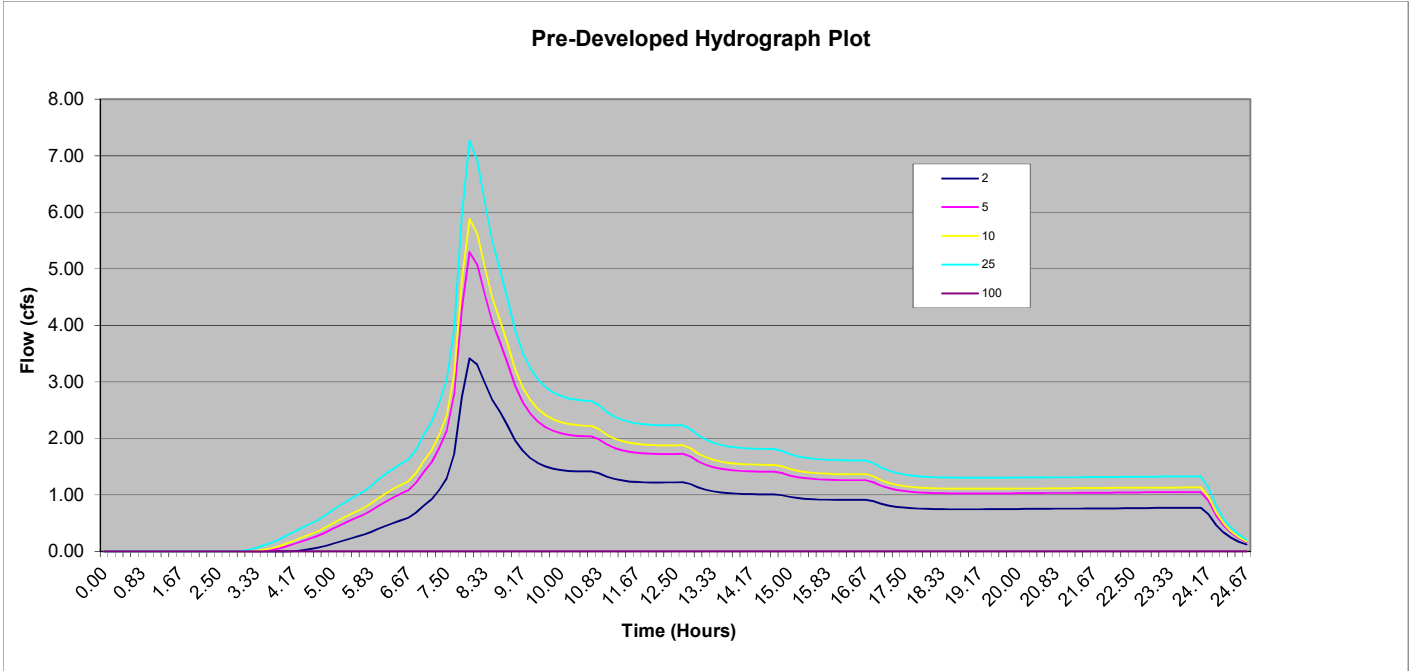

Pre-Developed Hydrographs						
Year	=====>	2	5	10	25	100
Qpeak	cfs =>	3.42	5.30	5.88	7.26	0.00
Volume	cf =>	73,183	107,346	117,913	142,981	-
Tpeak	min =>	480	480	480	480	10
Tpeak	hr =>	8.00	8.00	8.00	8.00	0.17
Hydrograph Name=>		2	5	10	25	100
Time	Time	Hyd	Hyd	Hyd	Hyd	Hyd
(min)	(hr)	(cfs)	(cfs)	(cfs)	(cfs)	(cfs)

Developed Hydrographs					
	2	5	10	25	100
Qpeak	6.14	8.99	9.87	11.94	0.00
Volume	84,150	119,380	130,207	155,802	-
Tpeak	470	470	470	470	10
Tpeak	7.83	7.83	7.83	7.83	0.17
Hydrograph Name=>	2	5	10	25	100
Time	Hyd	Hyd	Hyd	Hyd	Hyd
(cfs)	(cfs)	(cfs)	(cfs)	(cfs)	(cfs)

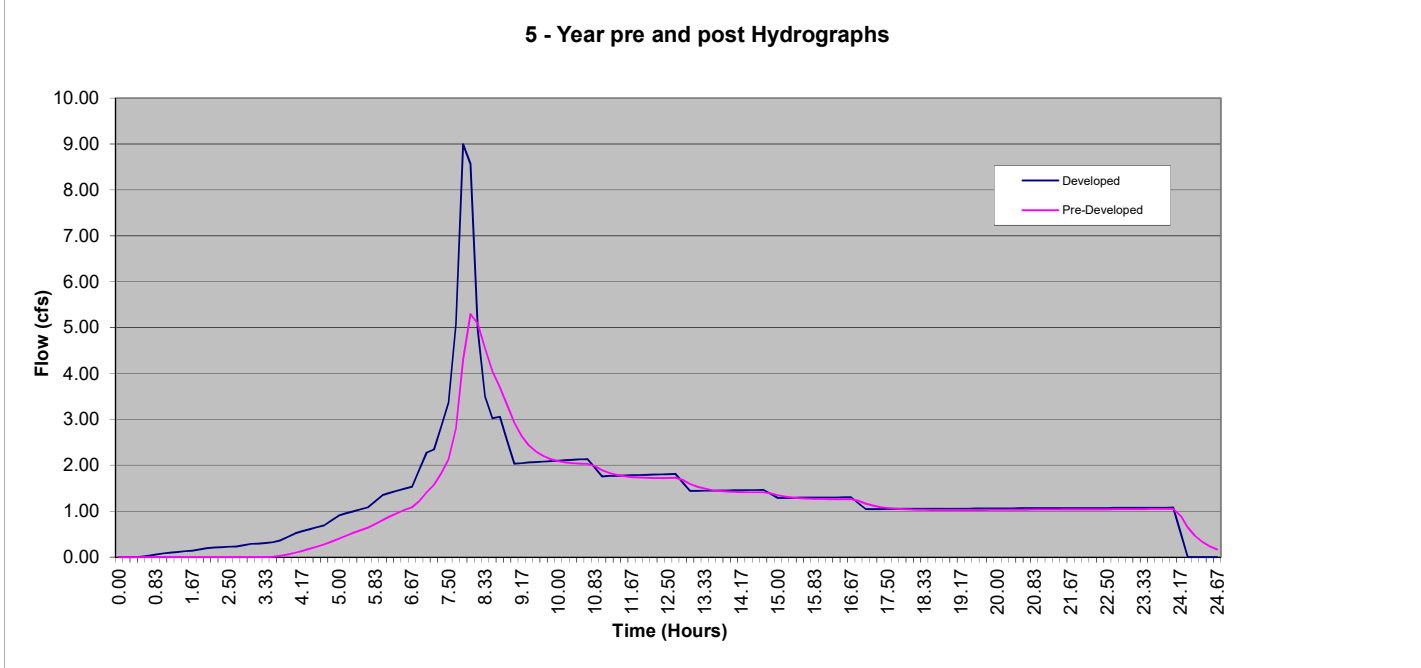
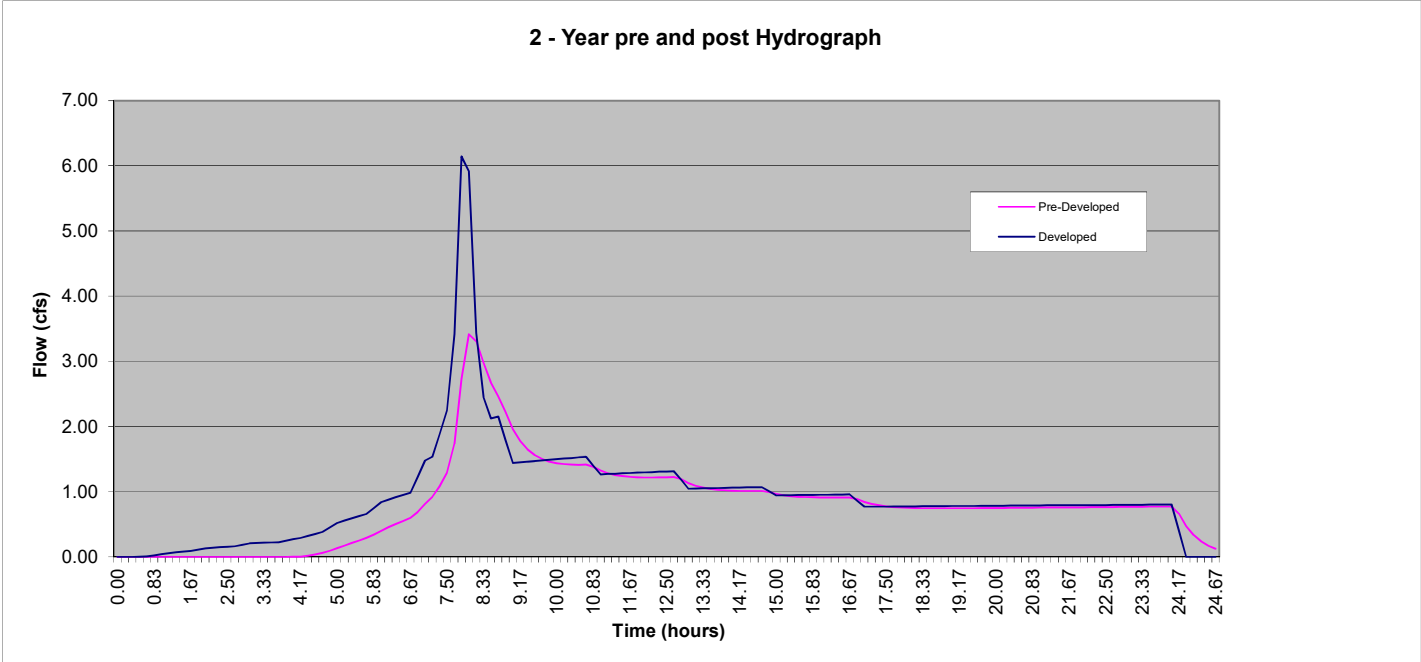

Pre-Developed Hydrographs						
Year	=====>	2	5	10	25	100
Qpeak	cfs =>	3.42	5.30	5.88	7.26	0.00
Volume	cf =>	73,183	107,346	117,913	142,981	-
Tpeak	min =>	480	480	480	480	10
Tpeak	hr =>	8.00	8.00	8.00	8.00	0.17
Hydrograph Name=>		2	5	10	25	100
Time	Time	Hyd	Hyd	Hyd	Hyd	Hyd
(min)	(hr)	(cfs)	(cfs)	(cfs)	(cfs)	(cfs)

Developed Hydrographs					
	2	5	10	25	100
	6.14	8.99	9.87	11.94	0.00
	84,150	119,380	130,207	155,802	-
	470	470	470	470	10
	7.83	7.83	7.83	7.83	0.17
	2	5	10	25	100
	Hyd	Hyd	Hyd	Hyd	Hyd
	(cfs)	(cfs)	(cfs)	(cfs)	(cfs)

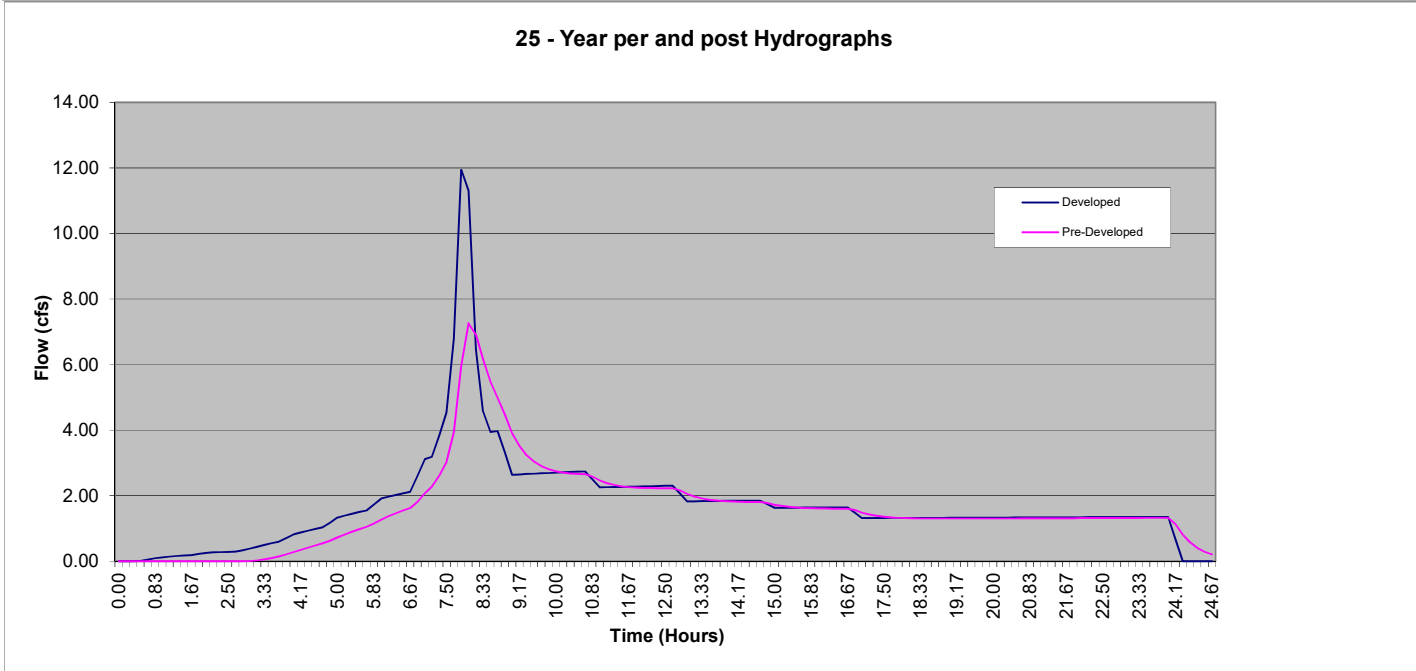
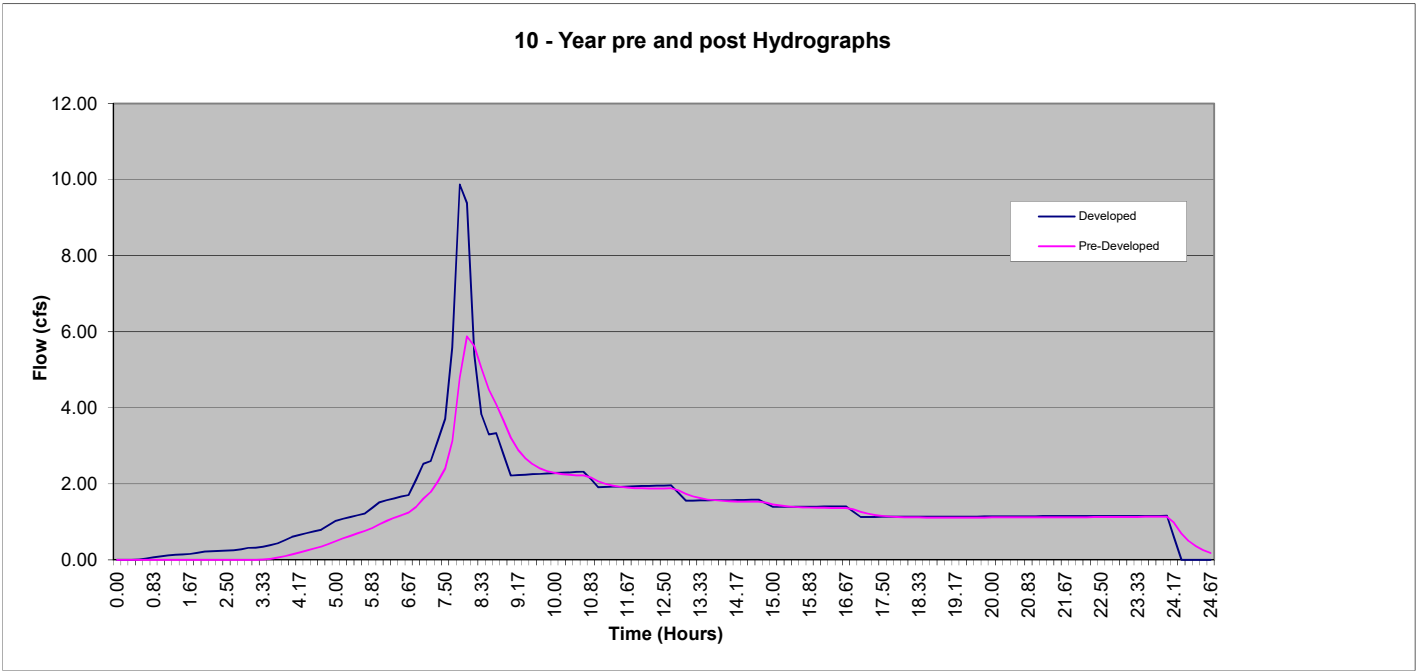

Pre-Developed Hydrographs						
Year	=====>	2	5	10	25	100
Qpeak	cfs =>	3.42	5.30	5.88	7.26	0.00
Volume	cf =>	73,183	107,346	117,913	142,981	-
Tpeak	min =>	480	480	480	480	10
Tpeak	hr =>	8.00	8.00	8.00	8.00	0.17
Hydrograph Name=>		2	5	10	25	100
Time	Time	Hyd	Hyd	Hyd	Hyd	Hyd
(min)	(hr)	(cfs)	(cfs)	(cfs)	(cfs)	(cfs)

Developed Hydrographs					
	2	5	10	25	100
Qpeak	6.14	8.99	9.87	11.94	0.00
Volume	84,150	119,380	130,207	155,802	-
Tpeak	470	470	470	470	10
Tpeak	7.83	7.83	7.83	7.83	0.17
Hydrograph Name=>	2	5	10	25	100
Time	Hyd	Hyd	Hyd	Hyd	Hyd
(cfs)	(cfs)	(cfs)	(cfs)	(cfs)	(cfs)

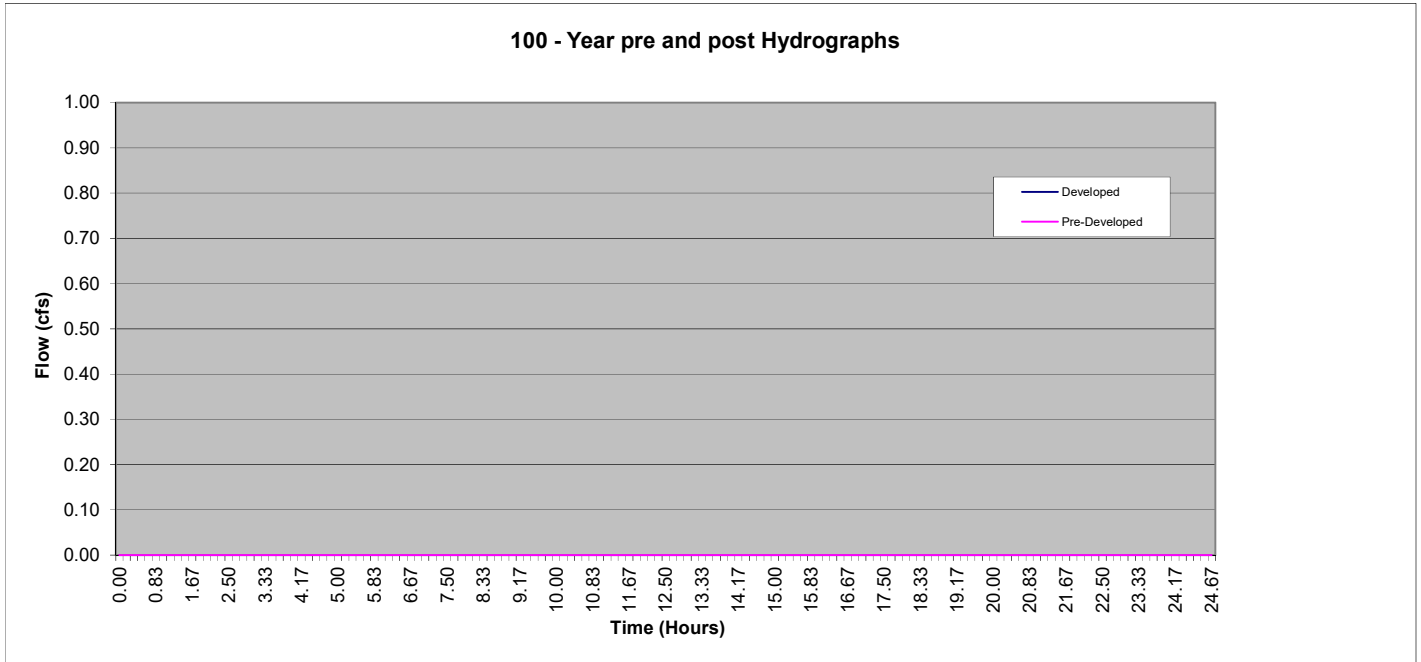

Project Name: Bull Run Terrace
Detention System Summary

Job # 019-035
 Date: 11/20/2019

Note: The detention system design is based on the King County Model "Facility Design Routine".

1) Detention Facility Design Input:		
2) Type of facility:	USER	
3) Pond side slopes:	3 NA in USER mode	
4) Pond storage depth:	4 ft (from bottom of pond to overflow)	
5) Vertical permeability	0 min/in	
6) Number of orifices:	2	
7) Riser dia. =>	12 in	
8) Orifice coefficient	0.62 (typically 0.62)	
9) IE - bottom orifice:	-2.5 ft (distance below bottom of pond - Negative #)	
10) Max Q Bottom Orif. #1	4.08 cfs	
11) Top Orif #2 Height =	2.8 ft	
12) Max Q Mid Orif. #3	0.00 cfs	Orifice not being used
13) Mid Orif #3 Height =	0.90 ft	Orifice not being used

Detention Facility Design Results:

Performance year	Developed Inflow cfs	Pre-Developed Outflow cfs	Actual Outflow cfs	Peak Stage ft	Storage cf
100	0	0	0	0	-
25	11.94	7.26	7.07	4.00	12,323
10	9.87	5.88	5.71	3.27	9,696
5	8.99	5.30	4.77	2.94	8,562
2	6.14	3.42	3.23	1.57	4,252
Required Storage =====					12,323

Total Q =	Bottom Orif. 4.08	Middle Orif. 0.00	Top Orif. 2.99	Optional Weir Design (for top orifice)
Head (ft) =	6.50	0.00	1.20	1.16 La (ft)
Dist. from bottom of pond (ft) =	-2.50	NA	2.80	132.65 < deg.
Orif. Dia. (in) =	7.68	0.00	10.03	Weir is an option

FLOW CONTROL STRUCTURE SCHEMATIC

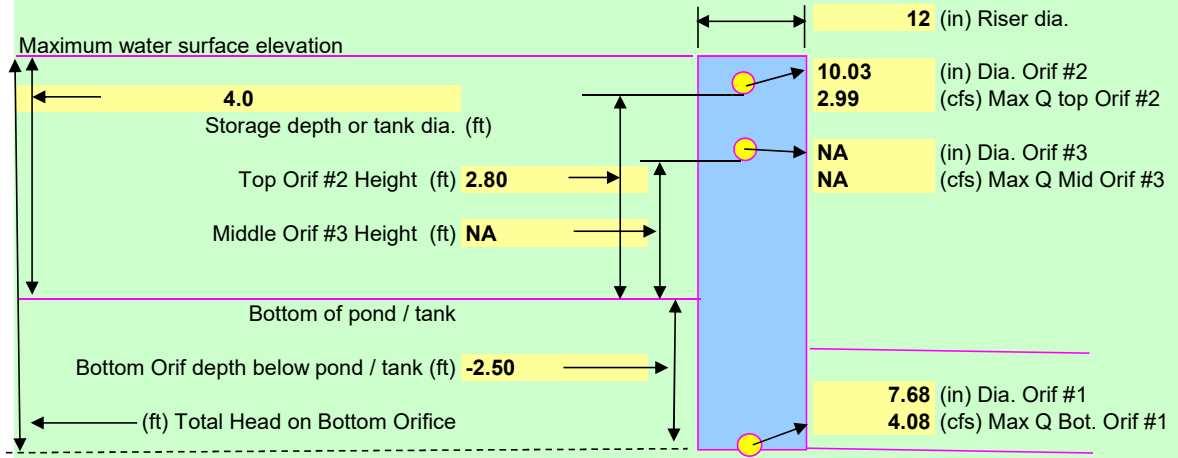

Project Name: Bull Run Terrace
 Detention Facility Type

Job # 019-035
 Date: 11/20/2019

Detention Facility Type:

USER

L = NA ft
 W = 40.0 ft
 D = 4.0 ft
 Pond Area = NA sf

DETENTION POND
 NA

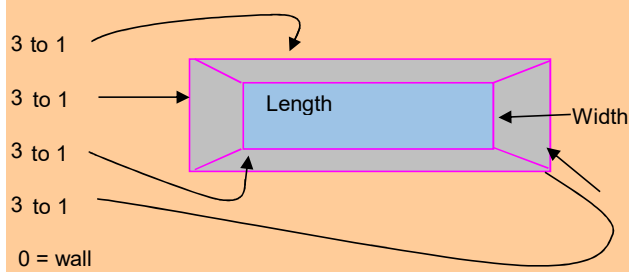

DETENTION TANK
 NA

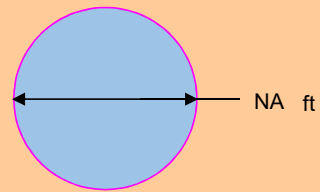

USER DEFINED POND

Pond Geometry

Stage (ft)	Area (sf)
0	2,443
1	2,750
2	3,070
3	3,405
4	3,754
5	4,000
6	4,500
7	5,000
8	5,500
9	6,000
10	6,500
11	7,000
12	7,500
13	8,000
14	8,500
15	9,000



All Storm Hydrographs Routed Through The Detention Facility

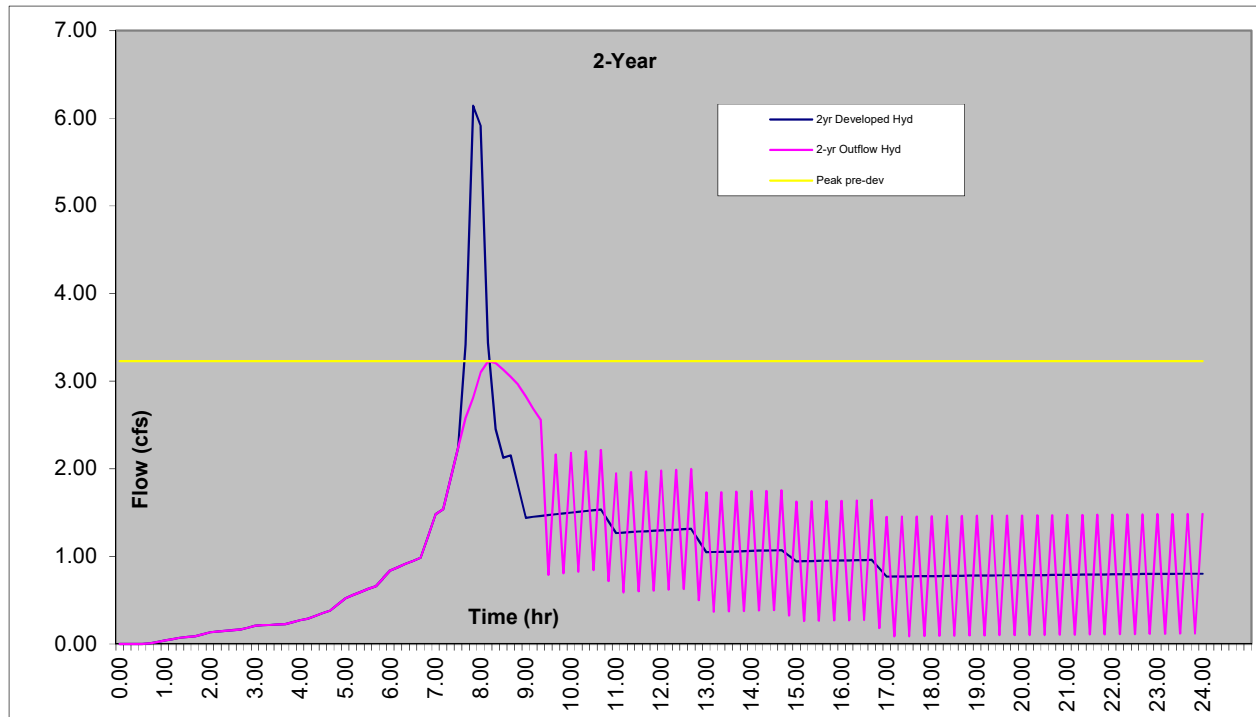
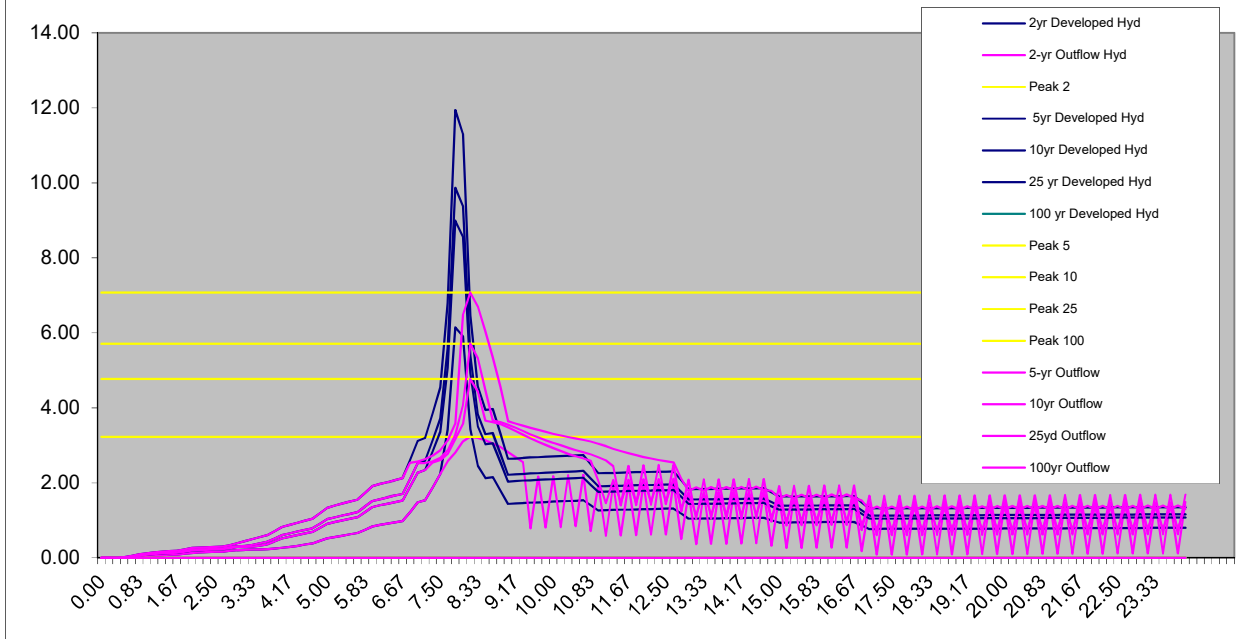

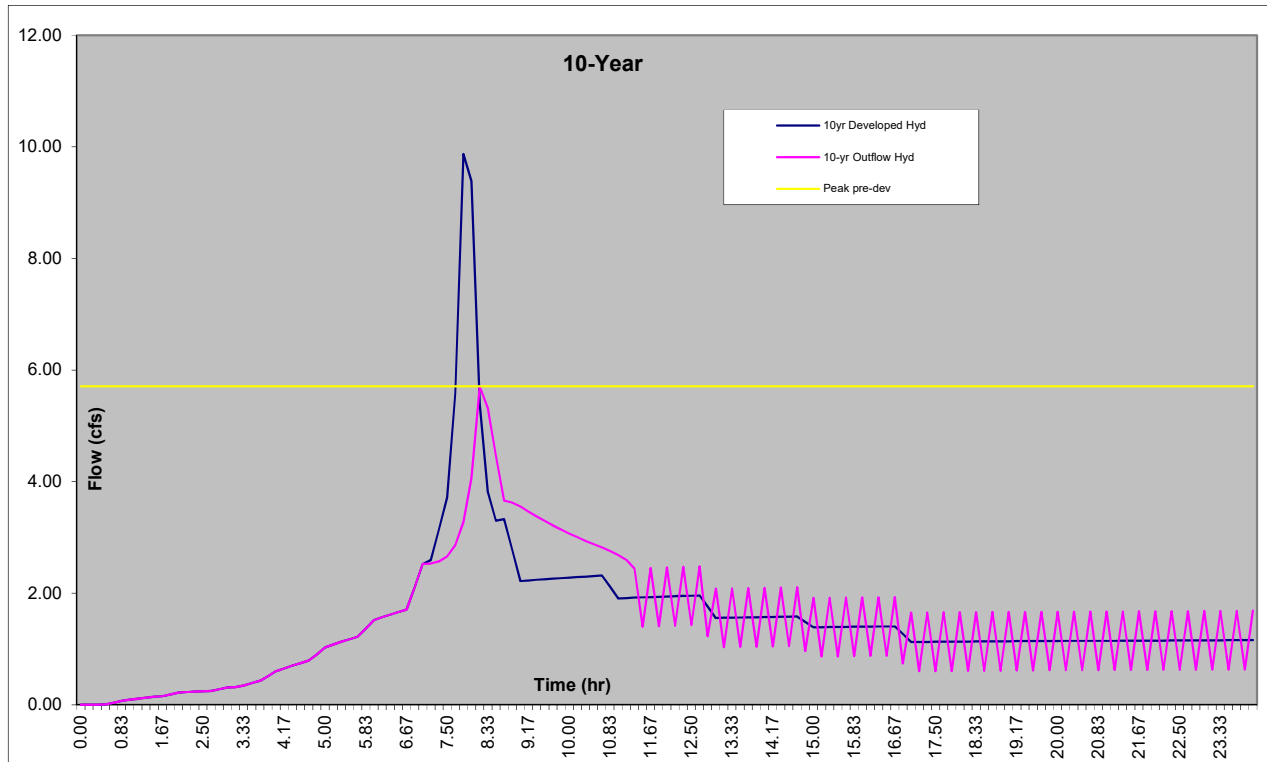
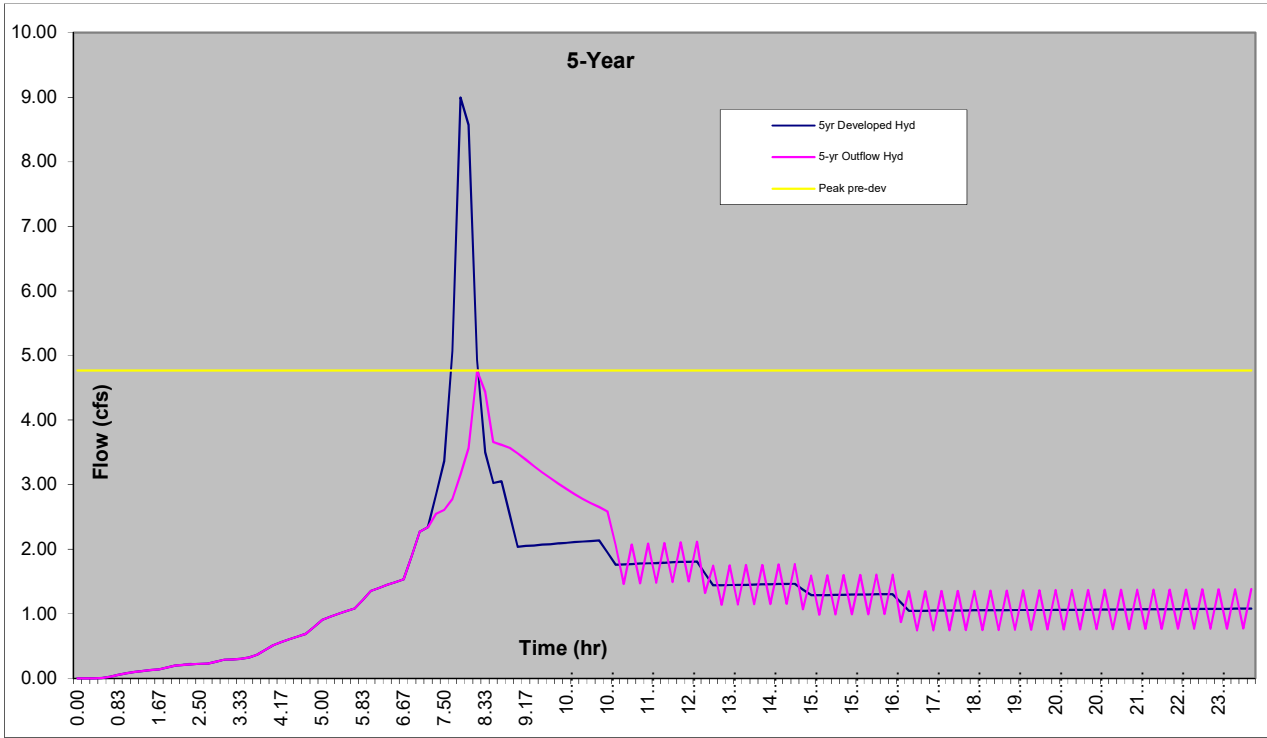

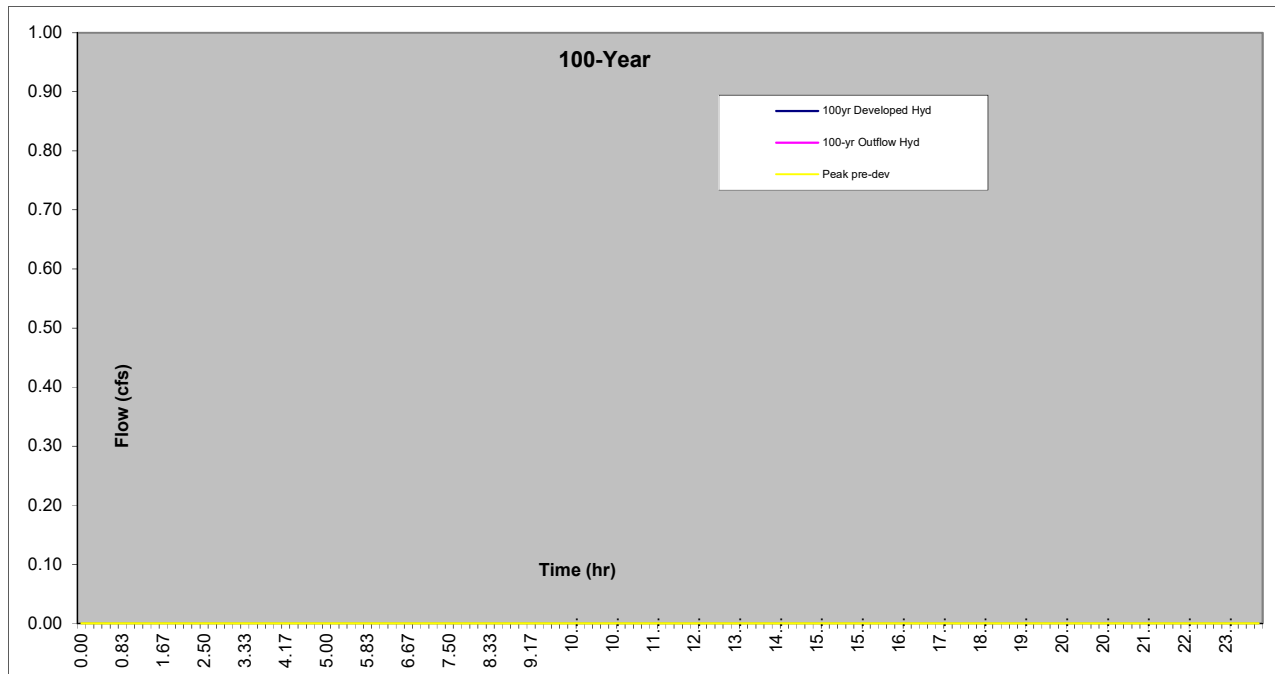
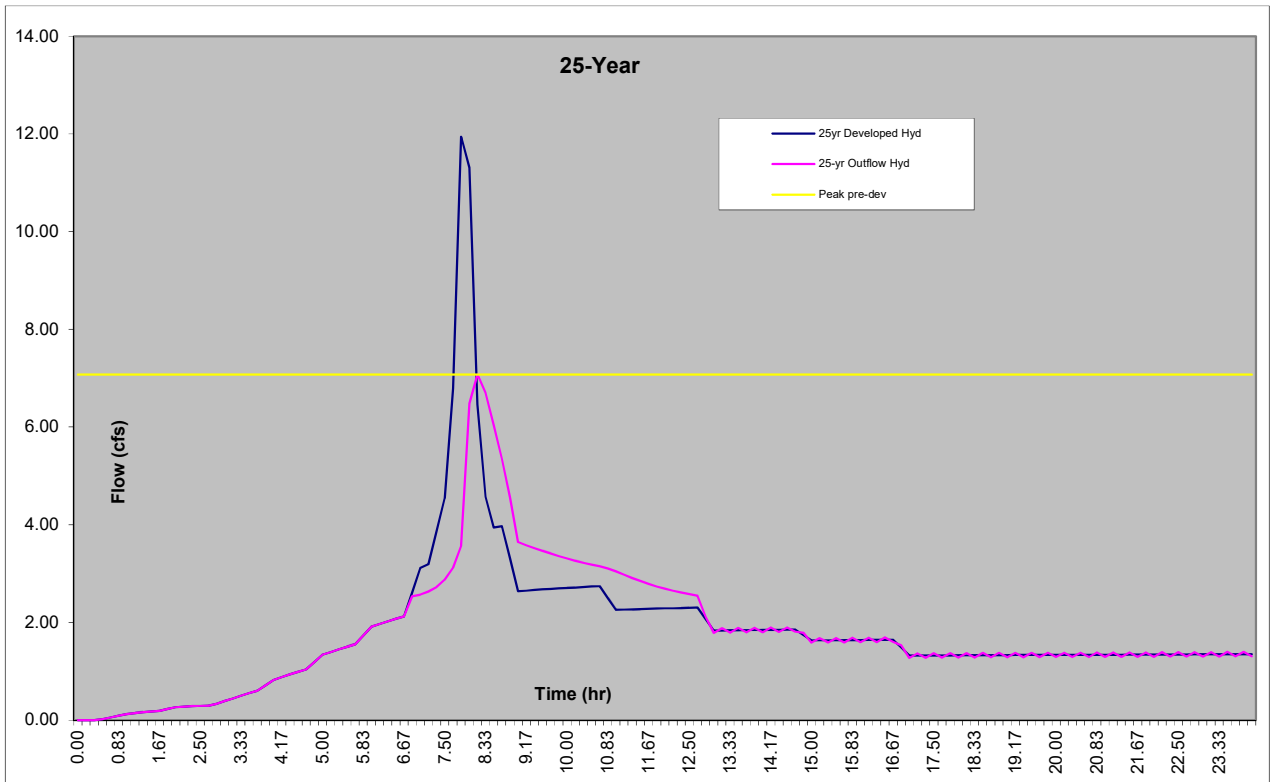

Project Name: Bull Run Terrace
Stage Storage Summary

Job # 019-035
 Date: 11/20/2019

Stage ft	Storage cf	Discharge cfs
-	-	-
0.05	-	0.36
0.10	-	0.51
0.15	-	0.62
0.20	-	0.72
0.25	-	0.80
0.30	-	0.88
0.35	-	0.95
0.40	-	1.01
0.45	-	1.07
0.50	-	1.13
0.55	-	1.19
0.60	-	1.24
0.65	-	1.29
0.70	-	1.34
0.75	-	1.39
0.80	-	1.43
0.85	-	1.48
0.90	-	1.52
0.95	-	1.56
1.00	-	1.60
1.05	-	1.64
1.10	-	1.68
1.15	-	1.72
1.20	-	1.75
1.25	-	1.79
1.30	-	1.82
1.35	-	1.86
1.40	-	1.89
1.45	-	1.93
1.50	-	1.96
1.55	-	1.99
1.60	-	2.02
1.65	-	2.06
1.70	-	2.09
1.75	-	2.12
1.80	-	2.15
1.85	-	2.18
1.90	-	2.21
1.95	-	2.23
2.00	-	2.26
2.05	-	2.29
2.10	-	2.32
2.15	-	2.35
2.20	-	2.37
2.25	-	2.40
2.30	-	2.43
2.35	-	2.45
2.40	-	2.48
2.45	-	2.50
2.50	-	2.53
2.55	129.83	2.56
2.60	259.65	2.58
2.65	389.48	2.61
2.70	519.30	2.63
2.75	649.13	2.65
2.80	778.95	2.68
2.85	908.78	2.70
2.90	1,038.60	2.73
2.95	1,168.43	2.75
3.00	1,298.25	2.77
3.05	1,428.08	2.79
3.10	1,557.90	2.82
3.15	1,687.73	2.84
3.20	1,817.55	2.86
3.25	1,947.38	2.88

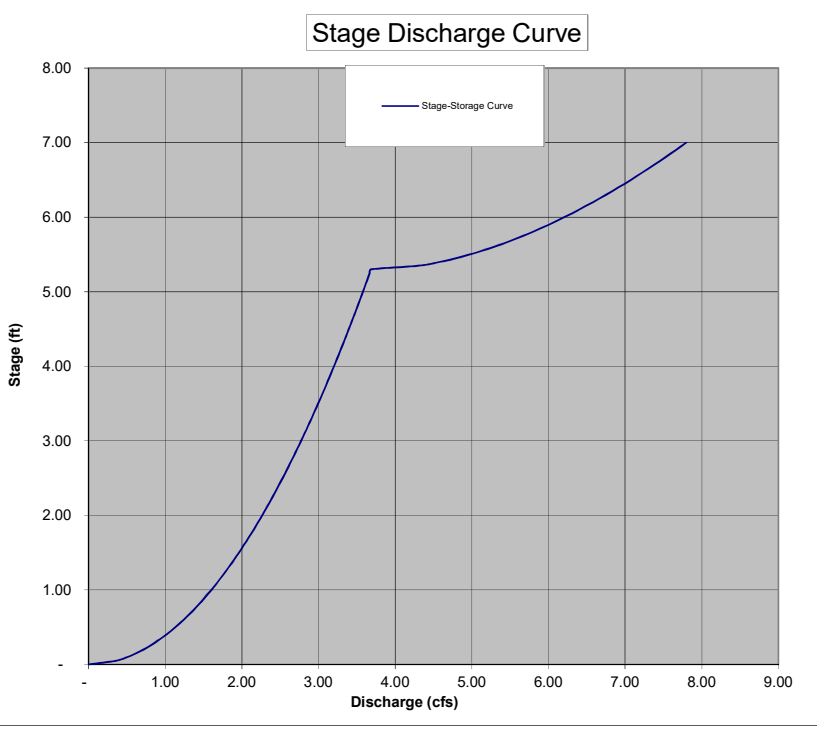
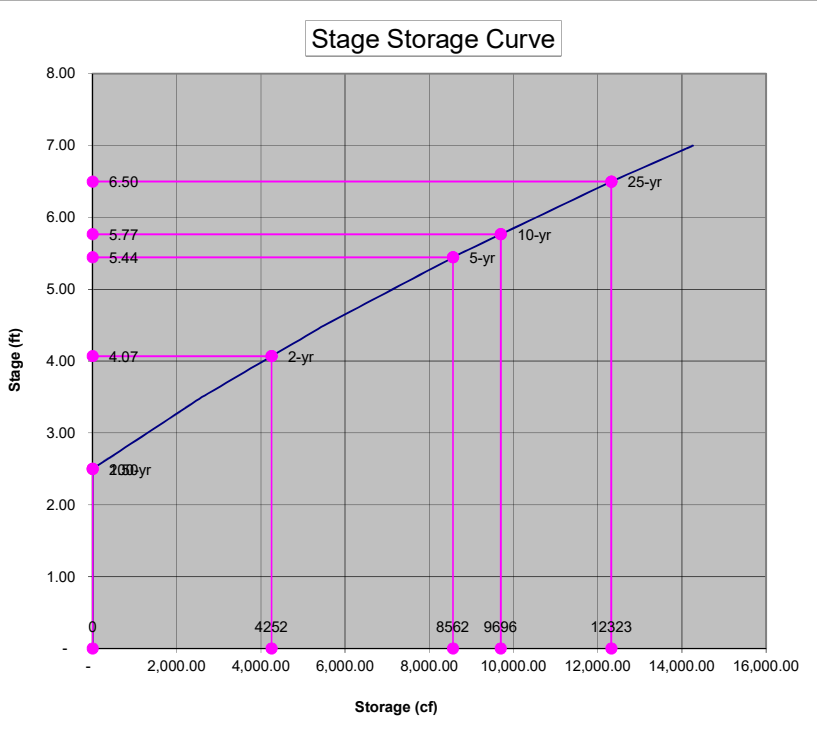

Stage ft	Storage cf	Discharge cfs
3.30	2,077.20	2.91
3.35	2,207.03	2.93
3.40	2,336.85	2.95
3.45	2,466.68	2.97
3.50	2,596.50	2.99
3.55	2,742.00	3.02
3.60	2,887.50	3.04
3.65	3,033.00	3.06
3.70	3,178.50	3.08
3.75	3,324.00	3.10
3.80	3,469.50	3.12
3.85	3,615.00	3.14
3.90	3,760.50	3.16
3.95	3,906.00	3.18
4.00	4,051.50	3.20
4.05	4,197.00	3.22
4.10	4,342.50	3.24
4.15	4,488.00	3.26
4.20	4,633.50	3.28
4.25	4,779.00	3.30
4.30	4,924.50	3.32
4.35	5,070.00	3.34
4.40	5,215.50	3.36
4.45	5,361.00	3.38
4.50	5,506.50	3.39
4.55	5,668.38	3.41
4.60	5,830.25	3.43
4.65	5,992.13	3.45
4.70	6,154.00	3.47
4.75	6,315.88	3.49
4.80	6,477.75	3.51
4.85	6,639.63	3.52
4.90	6,801.50	3.54
4.95	6,963.38	3.56
5.00	7,125.25	3.58
5.05	7,287.13	3.60
5.10	7,449.00	3.61
5.15	7,610.88	3.63
5.20	7,772.75	3.65
5.25	7,934.63	3.67
5.30	8,096.50	3.68
5.35	8,258.38	4.31
5.40	8,420.25	4.58
5.45	8,582.13	4.79
5.50	8,744.00	4.97
5.55	8,922.98	5.14
5.60	9,101.95	5.28
5.65	9,280.93	5.42
5.70	9,459.90	5.55
5.75	9,638.88	5.67
5.80	9,817.85	5.79
5.85	9,996.83	5.90
5.90	10,175.80	6.00
5.95	10,354.78	6.11
6.00	10,533.75	6.21
6.05	10,712.73	6.30
6.10	10,891.70	6.40
6.15	11,070.68	6.49
6.20	11,249.65	6.58
6.25	11,428.63	6.66
6.30	11,607.60	6.75
6.35	11,786.58	6.83
6.40	11,965.55	6.91
6.45	12,144.53	6.99
6.50	12,323.50	7.07
6.55	12,517.35	7.15
6.60	12,711.20	7.23
6.65	12,905.05	7.30
6.70	13,098.90	7.38
6.75	13,292.75	7.45
6.80	13,486.60	7.52
6.85	13,680.45	7.59

Stage ft	Storage cf	Discharge cfs
6.90	13,874.30	7.66
6.95	14,068.15	7.73
7.00	14,262.00	7.80

Project Name: Bull Run Terrace

Rectangular, Sharp Crested Weir Calculations

Job # 019-035
 Date: 11/20/2019

Weir Equation: $Q = C(L-0.2H)H^{3/2}$

- Q = Flow over weir (cfs)
- C = $3.27 + 0.40 H/P$ (ft)
- L = Adjusted length of weir ($L_a - 0.1H \times 2$) this is to account for side constraints
- L_a = Actual length of weir along pipes interior circumference (ft)
- H = Distance from bottom of weir to maximum head (ft)
- P = Distance from bottom of weir to outfall invert elevation (ft)
- D = Inside riser pipe diameter (in)
- < = Angle of opening for weir (maximum 180 degrees)

Given:

Q	2.99	cfs
H	1.20	ft
P	5.30	ft
D	12	in

Find:

C	3.36	ft
L	0.92	ft
L_a	1.16	ft
<	133	degrees

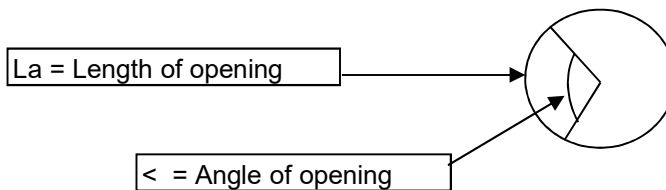
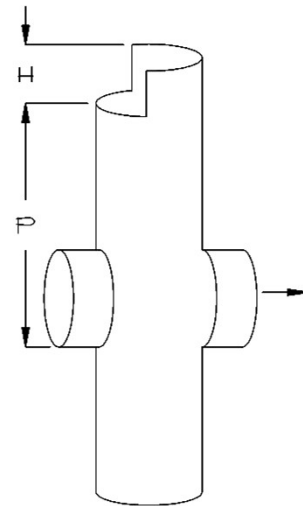

CDS2015-4-C DESIGN NOTES

CDS2015-4-C RATED TREATMENT CAPACITY IS 0.7 CFS (19.8 L/s) OR PER LOCAL REGULATIONS. MAXIMUM HYDRAULIC INTERNAL BYPASS CAPACITY IS 10.0 CFS (283 L/s). IF THE SITE CONDITIONS EXCEED 10.0 (283 L/s) CFS, AN UPSTREAM BYPASS STRUCTURE IS REQUIRED.

THE STANDARD CDS2015-4-C CONFIGURATION IS SHOWN. ALTERNATE CONFIGURATIONS ARE AVAILABLE AND ARE LISTED BELOW. SOME CONFIGURATIONS MAY BE COMBINED TO SUIT SITE REQUIREMENTS.

CONFIGURATION DESCRIPTION

- GRATED INLET ONLY (NO INLET PIPE)
- GRATED INLET WITH INLET PIPE OR PIPES
- CURB INLET ONLY (NO INLET PIPE)
- CURB INLET WITH INLET PIPE OR PIPES
- SEPARATE OIL BAFFLE (SINGLE INLET PIPE REQUIRED FOR THIS CONFIGURATION)
- SEDIMENT WEIR FOR NIDEP / NUCAT CONFORMING UNITS

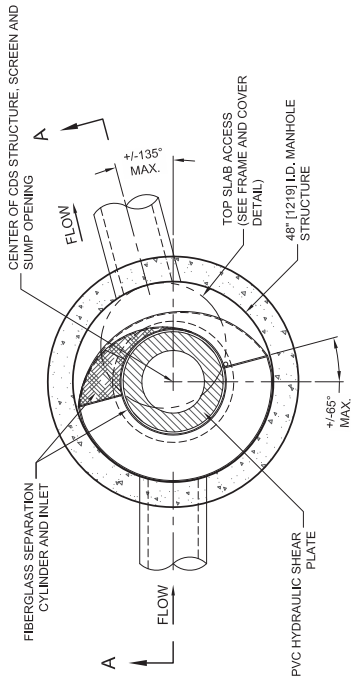

PLAN VIEW B-B
N.T.S.

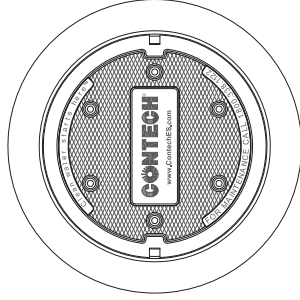

FRAME AND COVER
(DIAMETER VARIES)
N.T.S.

SITE SPECIFIC DATA REQUIREMENTS		
STRUCTURE ID		
WATER QUALITY FLOW RATE (CFS OR L/s)	*	
PEAK FLOW RATE (CFS OR L/s)	*	
RETURN PERIOD OF PEAK FLOW (YRS)	*	
SCREEN APERTURE (2400 OR 4700)	*	
PIPE DATA:		
I.E.	MATERIAL	DIAMETER
INLET PIPE 1	*	*
INLET PIPE 2	*	*
OUTLET PIPE	*	*
RIM ELEVATION		
ANTI-FLOTATION BALLAST	WIDTH	HEIGHT
	*	*
NOTES/SPECIAL REQUIREMENTS:		
* PER ENGINEER OF RECORD		

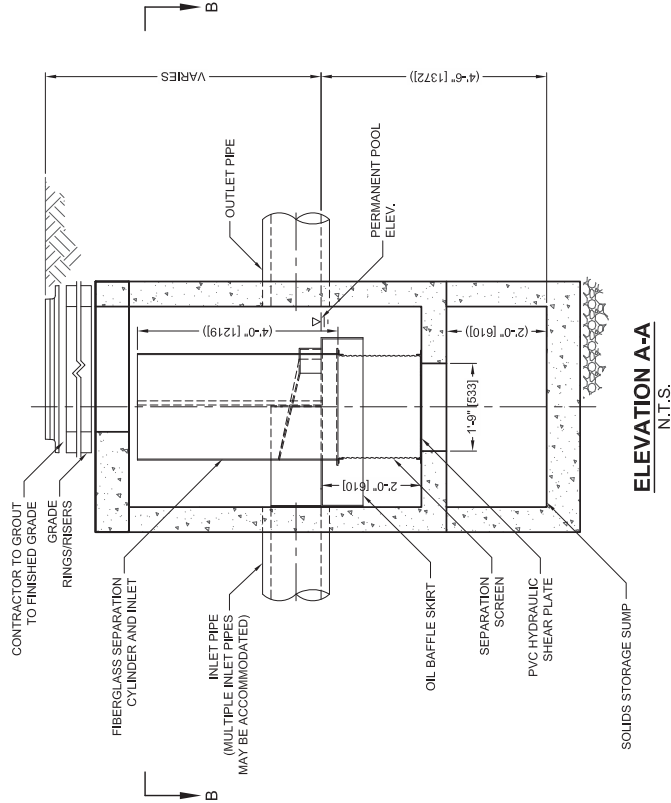

ELEVATION A-A
N.T.S.

- GENERAL NOTES:**
- CONTECH TO PROVIDE ALL MATERIALS UNLESS NOTED OTHERWISE.
 - CONTRACTOR TO PROVIDE ALL MATERIALS FOR THE STRUCTURE. ALL DIMENSIONS MAY VARY.
 - FOR FABRICATION DRAWINGS WITH DETAILED STRUCTURE DIMENSIONS AND WEIGHTS, PLEASE CONTACT YOUR CONTECH ENGINEERED SOLUTIONS LLC REPRESENTATIVE. www.conteches.com
 - CDS WATER QUALITY STRUCTURE SHALL BE IN ACCORDANCE WITH ALL DESIGN DATA AND INFORMATION CONTAINED IN THIS DRAWING.
 - STRUCTURE SHALL MEET AASHTO HS20 AND CASTINGS SHALL MEET HS20 (AASHTO M 308) LOAD RATING, ASSUMING GROUNDWATER ELEVATION AT, OR BELOW, THE OUTLET PIPE INVERT ELEVATION. ENGINEER OF RECORD TO CONFIRM ACTUAL GROUNDWATER ELEVATION.
 - PVC HYDRAULIC SHEAR PLATE IS PLACED ON SHELF AT BOTTOM OF SCREEN CYLINDER. REMOVE AND REPLACE AS NECESSARY DURING MAINTENANCE CLEANING.

INSTALLATION NOTES:

- ANY SUB-BASE, BACKFILL DEPTH, AND/OR ANTI-FLOTATION PROVISIONS ARE SITE-SPECIFIC DESIGN CONSIDERATIONS AND SHALL BE SPECIFIED BY ENGINEER OF RECORD.
- BACKFILL TO BE PROVIDED WITH SUFFICIENT LIFTING AND REACH CAPACITY TO LIFT AND SET THE CDS MANHOLE STRUCTURE. LIFTING OUTLINES PROVIDED.
- CONTRACTOR TO ADD JOINT SEALANT BETWEEN ALL STRUCTURE SECTIONS, AND ASSEMBLE STRUCTURE.
- CONTRACTOR TO PROVIDE, INSTALL, AND GROUT PIPES. MATCH PIPE INVERTS WITH ELEVATIONS SHOWN.
- CONTRACTOR TO TAKE APPROPRIATE MEASURES TO ASSURE UNIT IS WATER TIGHT, HOLDING WATER TO FLOWLINE INVERT MINIMUM. IT IS SUGGESTED THAT ALL JOINTS BELOW PIPE INVERTS ARE GROUTED.

CDS2015-4-C
INLINE CDS
STANDARD DETAIL



www.conteches.com
9025 Centre Pointe Dr., Suite 400, West Chester, OH 45069
600-335-1122 513-645-7000 513-645-7993 FAX



CONTECH ENGINEERED SOLUTIONS LLC
10000 WILSON BLVD., SUITE 100, WEST CHESTER, OH 45069